

fiok

MADE IN ITALY



SERRAMENTI-PERSIANE-PORTE
WINDOWS-BLINDS-DOORS

CATALOGO

46-D

2016

CONDIZIONI GENERALI DI VENDITA

ORDINI

Le ordinazioni si intendono accettate alle condizioni indicate nella conferma d'ordine e non potranno essere annullate né parzialmente né totalmente dal Committente. In mancanza di conferma d'ordine valgono le nostre condizioni generali di vendita.

CONSEGNE

I termini di consegna pattuiti decorrono dalla data di definizione di tutti i dettagli inerenti l'ordinazione e saranno nel possibile rispettati. Eventuali ritardi, conseguenze di disguidi indipendenti dalla nostra volontà, non potranno essere motivo di annullamento o di richieste di indennizzi di nessun genere.

SPEDIZIONI

La merce viene resa franco nostro stabilimento e spedita, salvo accordi diversi, con il mezzo più vantaggioso. La merce viaggerà sempre a rischio e pericolo del committente. Eventuali assicurazioni dovranno essere esplicitamente richieste e saranno fatturate al costo. L'imballo è sempre a carico del committente ed addebitato al costo.

GARANZIA

Tutti i nostri utensili sono sottoposti ad accurati controlli e sono completamente garantiti. Si declina qualsiasi responsabilità per danni diretti ed indiretti dovuti all'utilizzo improprio dei materiali, dal logorio, da danni causati dal trasporto, da modifiche effettuate senza la nostra approvazione od alla non osservanza delle norme e delle condizioni di impiego indicate su utensili, manuali o cataloghi e sito internet.

RESTITUZIONI E RECLAMI

Non si accettano restituzioni della merce, a nessun titolo, se non preventivamente autorizzate da FINK srl. I reclami per merce sbagliata o difettosa dovranno essere inviati alla nostra sede esclusivamente tramite documentazione scritta indicante il difetto riscontrato, entro 8 giorni dal ricevimento della merce.

PREZZI

I prezzi si intendono I.V.A. esclusa, che sarà applicata con l'aliquota vigente al momento della spedizione. La merce si intende fornita franco nostra fabbrica e l'imballo è a carico del committente. Salvo accordi particolari comprovati dalla conferma d'ordine, vengono applicati i prezzi di listino in vigore alla data dell'ordine della merce. Fori speciali a partire da € 8,00.

PAGAMENTI

Gli importi delle fatture vanno pagati per intero alle scadenze stabilite e direttamente a FINK srl. Non sono ammessi arrotondamenti o trattenute arbitrarie. Tutte le spese accessorie sono a carico del cliente. Il mancato rispetto dei termini di pagamento autorizza FINK srl, al recupero di ogni spesa accessoria, agli interessi maturati secondo quanto previsto dal D.Lgs 9/10/2002 n.231, ci riserviamo inoltre il diritto alla sospensione di eventuali ordini in corso. La merce rimane proprietà di FINK srl fino al pagamento totale della fornitura e delle eventuali spese accessorie.

DIRITTI D'AUTORE

Tutti i diritti sono riservati a norma di legge. FINK srl fa divieto a chiunque di copiare, riprodurre testi, disegni, illustrazioni in modo totale o parziale, senza il suo consenso scritto.

FORO COMPETENTE

Per qualsiasi controversia, il foro competente è esclusivamente quello di Monza. I contratti, anche se stipulati con acquirenti stranieri o per materiali forniti all'estero sono regolati dalla legislazione Italiana.

SPECIFICAZIONI E DISEGNI

I prodotti FINK srl sono soggetti a continue innovazioni; ci si riserva il diritto di apportare le modifiche ed i miglioramenti ritenuti opportuni senza incorrere in alcun tipo di obbligazione per quelli già venduti.

GENERAL TERMS OF SALE

ORDERS

Orders are accepted with the conditions indicated in the order confirmation and may neither be totally nor partially cancelled by the customer. Without an order confirmation are valid our general terms of sale.

DELIVERY TERMS

The delivery dates are only indicative and will be respected as much as possible and start from the date when all the details concerning the order are defined. Possible delays, due to unexpected events, that do not depend from our, will cannot be reason of claim, cancellation of the order or request for any compensation

SHIPMENTS

Goods are delivered ex-factory and with the most advantageous forwarding agent, except different agreements with the buyer. Freight costs and risks will be at the charge of the buyer. Shipment will be covered by insurance guarantee only if expressly requested by the buyer and charged at cost. No claim can be entertained in case of goods short delivered, damaged or lost in transit. Packing is at the charge of the buyer and debited at the real cost.

GUARANTEE

All our tools are carefully controlled and guaranteed. The guarantee does not include damages caused during the transport, defects due to wear, wrong or improper use, non maintenance, handlings or modifications made without our approval, the failure to comply with the safety rules and the instructions of use indicated on the tools, catalogues, guides or web-site.

RETURNS AND CLAIMS

Fink does not accept returns of the goods if not previously authorized. Claims for wrong or defective goods have to be communicated only in writing within 8 days from the receipt of the goods mentioning the description of the defect.

PRICES

Prices are considered ex-factory without V.A.T., which will be imposed with the share in force during the invoicing. The packing is at the charge of the buyer. Except particular agreements stated in the order confirmation we will apply the price-list in force at the moment of the order. Extra cost for special bores from € 8,00.

PAYMENTS

The invoices amounts have to be fully paid, on stated maturity, to Fink S.r.l. All extra charges are at the customer expense. Payments may not be rounded down or reduced under any circumstances. If the terms of payment are not honoured Fink S.r.l. can interrupt new supplies and debit all the due interests as well as any additional expense. The delivery terms will be automatically extended. The passing of property of the products supplied by Fink S.r.l. to the customer will take place after complete settlement of the invoices.

RESERVED OWNERSHIP RIGHTS

All rights are reserved in accordance with the law and international agreements. This catalogue not be reproduced or copied (even in part) without prior and written authorization on the part of Fink S.r.l.

PLACE OF JURISDICTION

For any legal matter the place of jurisdiction is Monza. The contracts, even if defined with foreign Buyers or for goods to be sent abroad, are regulated by the Italian legislation.

SPECIFICATION AND DRAWINGS

Our tools are subject to continuous innovations, we reserve the right to make improvements and modifications that we consider appropriate without incurring in any kind of duty for the products already sold.

THE PRICE-LIST 2011 CANCEL AND REPLACES THE PREVIOUS ONE.



GRUPPI PER FINESTRE PERSIANE PORTE

TOOLS FOR WINDOWS - BLINDS - DOORS

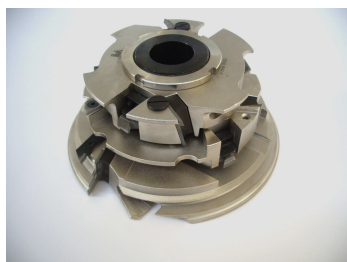

GRUPPI PER FINESTRE
TOOLS FOR WINDOWS
ARIA 4 - 12

ART. EW58-TH11-SH1

ECONOMIC WINDOW
per macchine tipo combinate

ART.S58-S68-S78-S90
LA66-JV68

PER TOUPIE, TENONATRICI
ANGOLI, CNC

ANCHE CON CASCADING

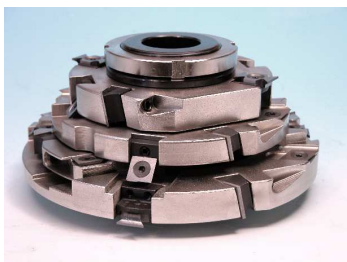

GRUPPI PER FINESTRE
TOOLS FOR WINDOWS

CON RAGGIATORI MOBILI O CON PLACCHETTE
PROFILATE AUTOPOSIZIONANTI E RIAFFILABILI
*with adjustable edge rounding knives
or with self-positioning profiled knives
which have the possibility to be
sharpened.*



GRUPPI PER ALZANTI SCORREVOLI
SET FOR SLIDING DOORS

TIPO GU, AGB, MAICO

ART. AS/GU AS/M



PERSIANE E SCURI

ASSISTENZA PER CERTIFICAZIONE SERRAMENTI
ADEGUAMENTO GRUPPI, SOSTITUZIONE COLTELLI
*ASSISTANCE IS AVAILABLE FOR THE CLEANING OF
CUTTER SETS, SUBSTITUTION OF KNIVES*

ART. 5/70 - 5/71 - 5/90 - 5/92



GRUPPI PER PORTE
SET FOR DOORS

ART. 5/57 - 5/67 - 5/68 - 5/79

ART. 5/36 - 5/136 - 5/137

CATALOGO 46 D 2016

EW 58 ARIA 4

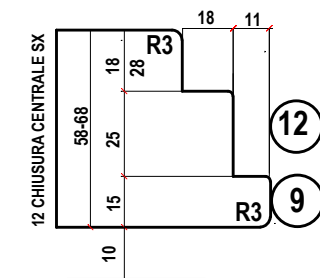
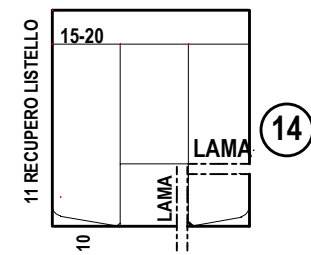
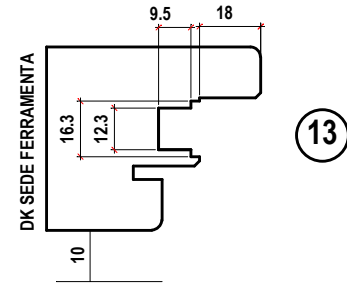
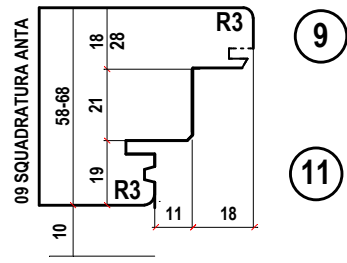
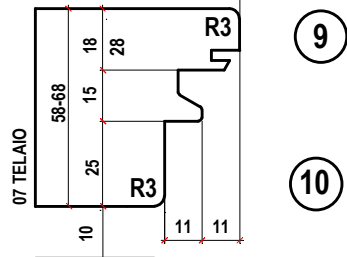
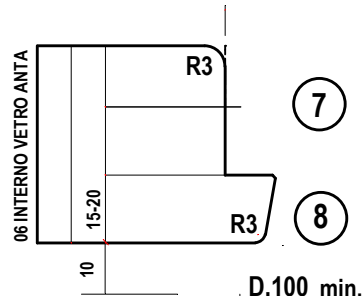
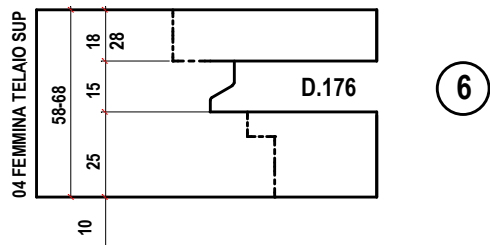
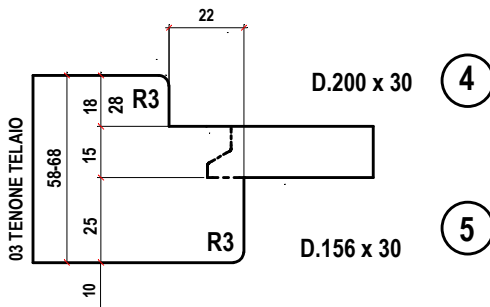
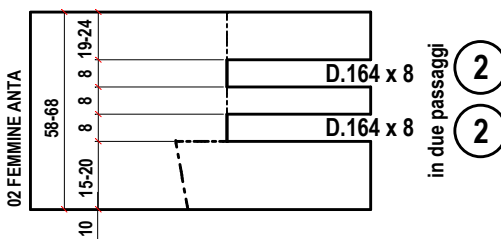
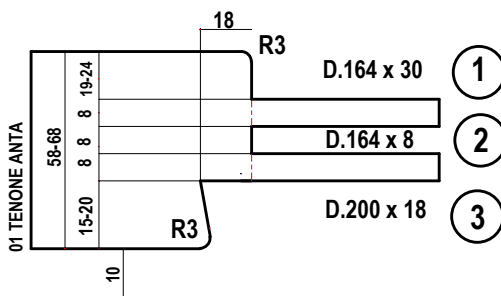
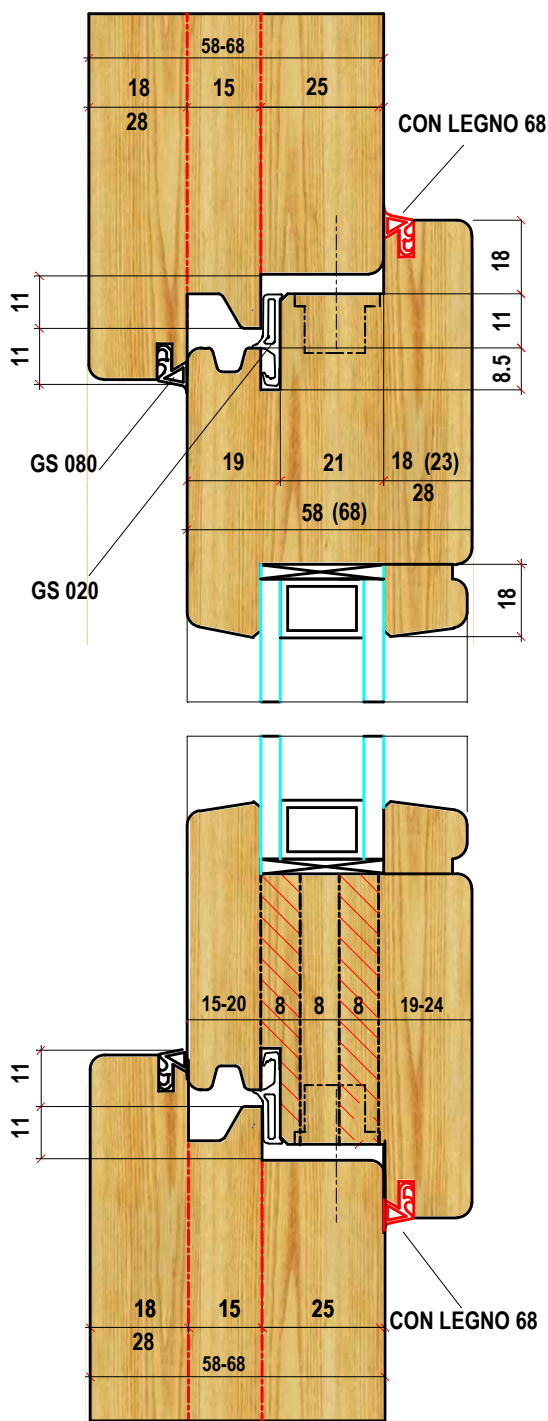

14 UTENSILI componibili
FORO 30 SENZA CANOTTO
D.MIN.100 D.MAX 200
SPESSORE LEGNO 58-68
ARIA 4 2-3 GUARNIZIONI

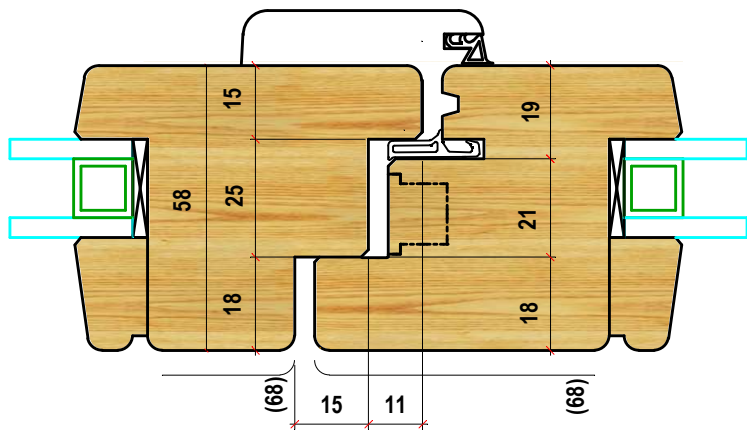

TH11 CON TENONI

SERIE DI UTENSILI IN 5 PEZZI: (A) TENONE ANTA
 (B) PROFILO INTERNO ANTA
 (C) PROFILO TELAIO e ANTA
 (D) ANTA SX e CONTROS.TELAIO
 (E) SEDE FERRAMENTA

2 GRUPPI OPTIONAL: (F) TENONE FEMMINE ANTA
 (G) RECUPERO LISTELLO

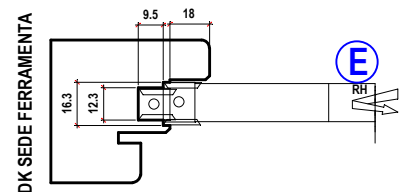
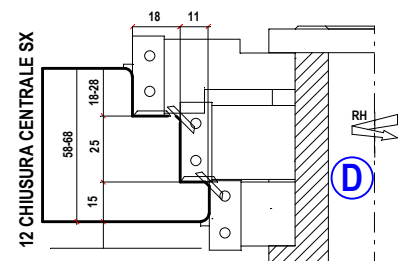
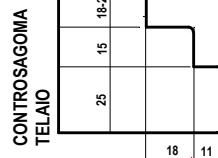
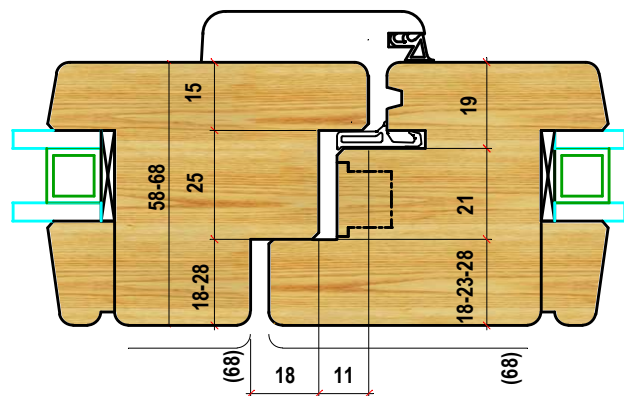
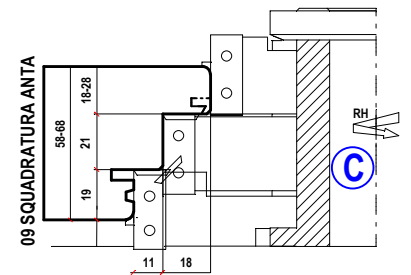
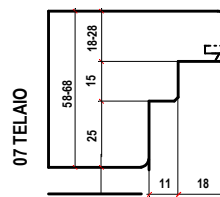
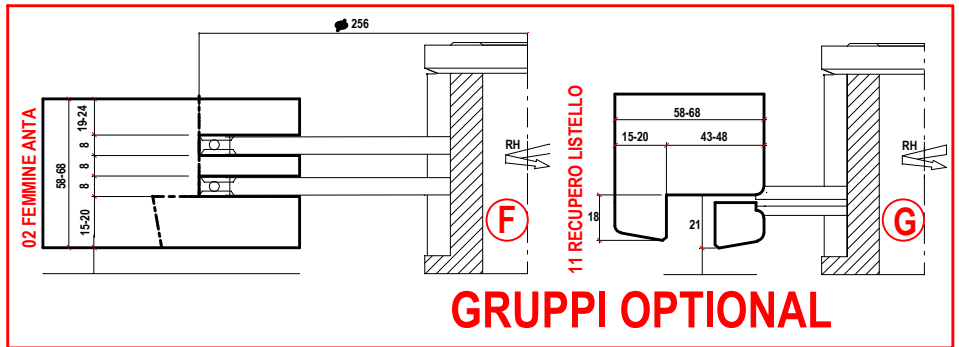
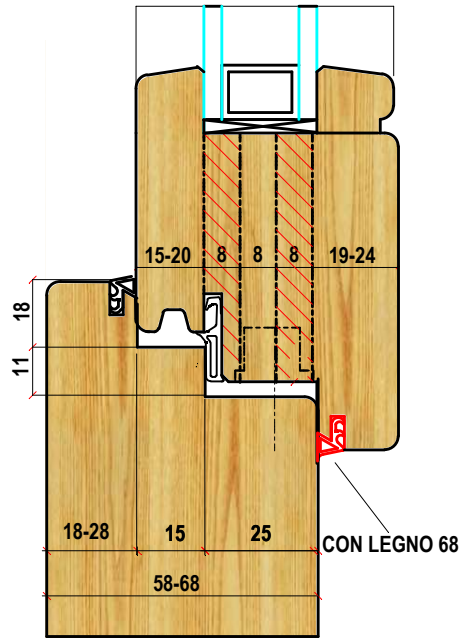
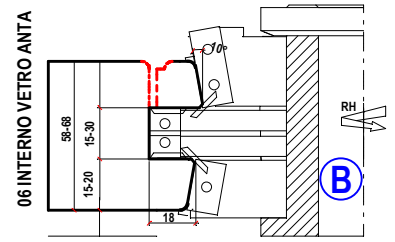
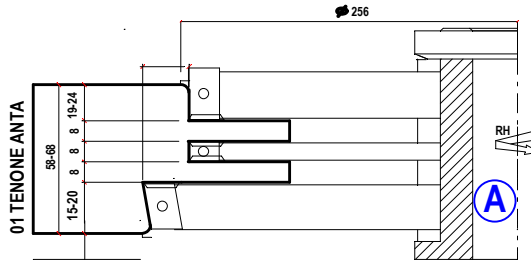
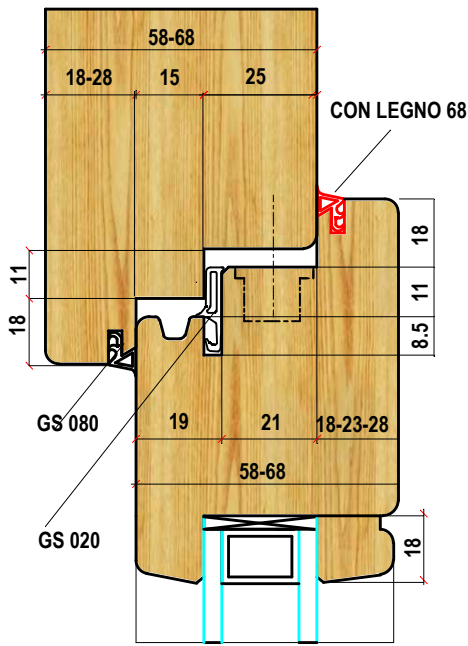

SH1 ARIA 12

GRUPPO PER INFISSI COMPOSTO DA:
 19 UTENSILI
 1 CANOTTO PORTA FRESE
 ANELLI DISTANZIATORI
 1 ANELLO DI CHIUSURA
 DISEGNI+ISTRUZIONI

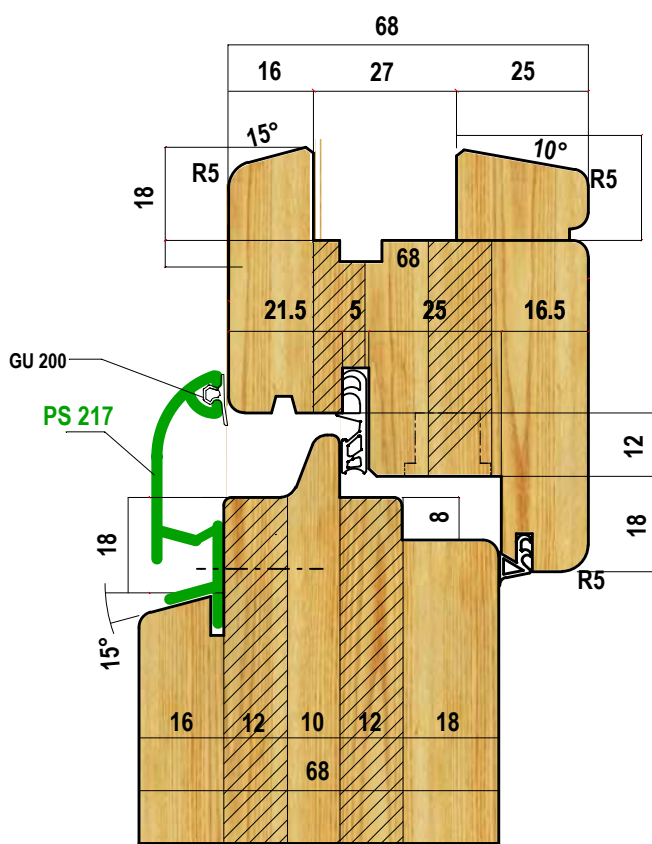
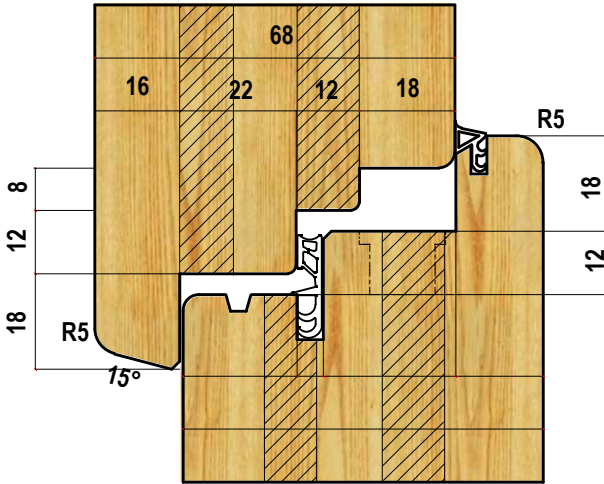

SEZIONE VERTICALE

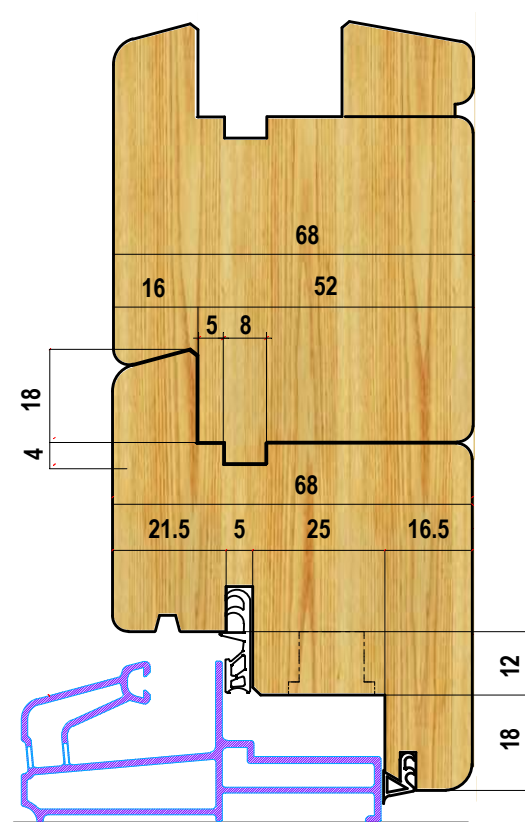

PORTA FINESTRA

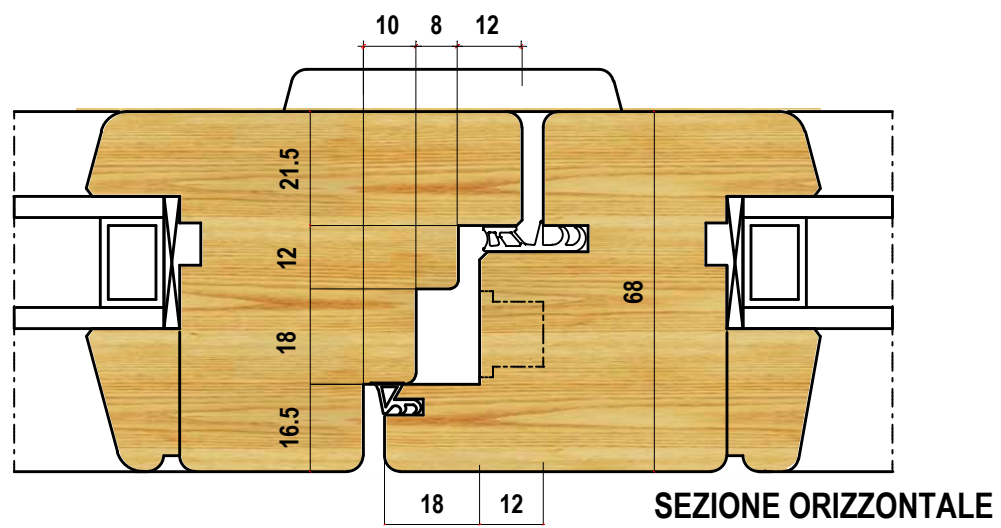

SEZIONE ORIZZONTALE

SH1 ARIA 12

TENONATURA TELAIO
TENONIG FRAME

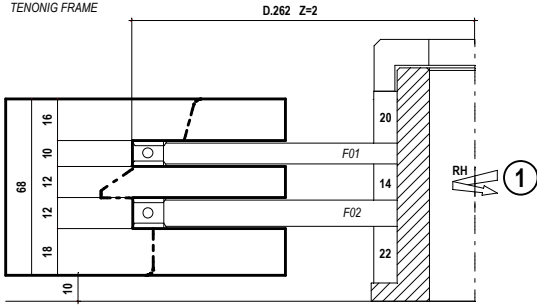

PROFILATURA MONTANTE CENTRALE ANTA SINISTRA
PROFILING CENTRAL JAMB LEFT SASH

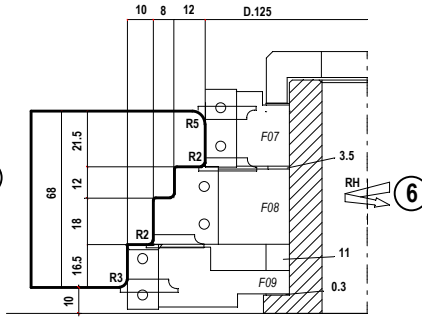

PROFILATURA TRAVERSO INFERIORE TELAIO
PROFILING LOWER CROSS FRAME

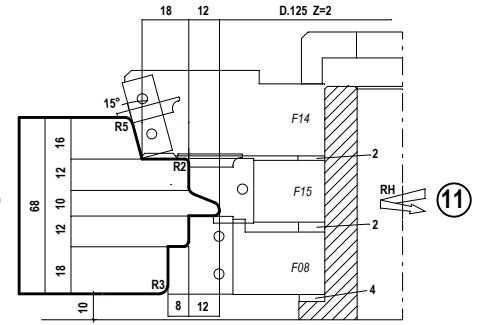

TENONATURA TELAIO
TENONIG FRAME

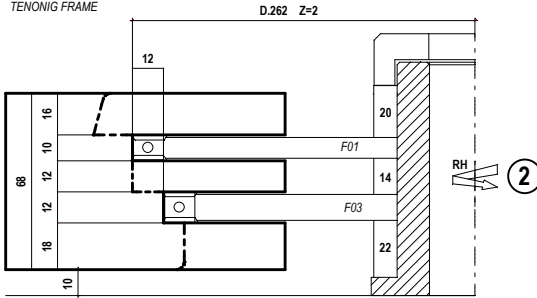

SQUADRATURA ANTA
SQUARING SASH

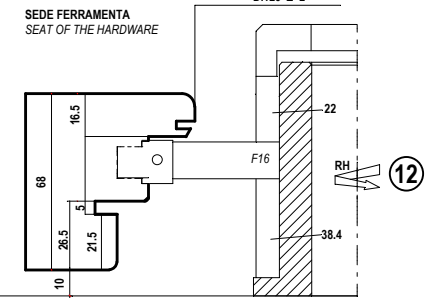
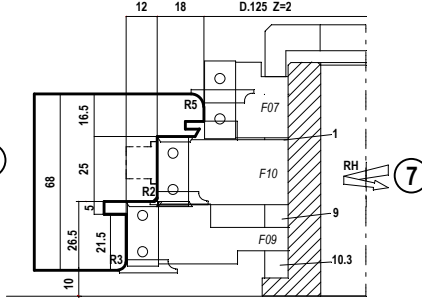

TENONATURA TELAIO
TENONIG FRAME

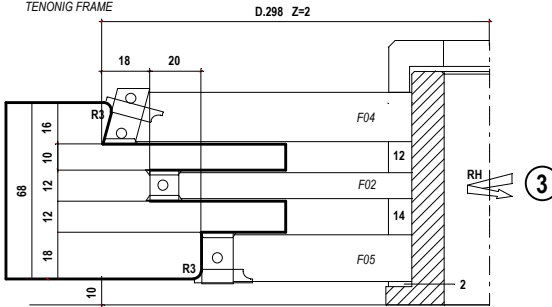

PROFILATURA INFERIORE ANTA
PROFILING LOWER SASH

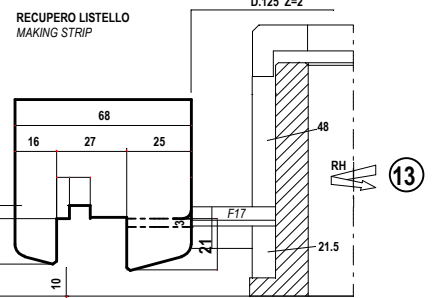
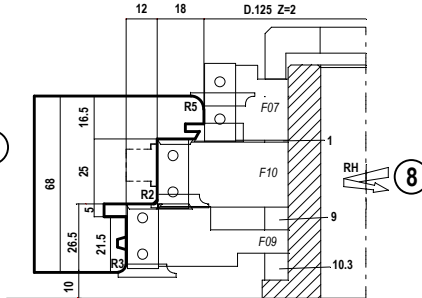

TENONI MONTANTI ANTA
TENONING SASH JAMBS

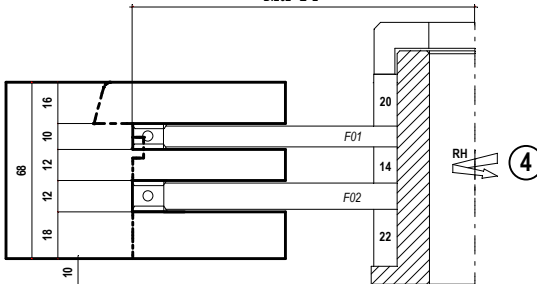

PROFILATURA INTERNO ANTA
PROFILING INTERNAL SASH

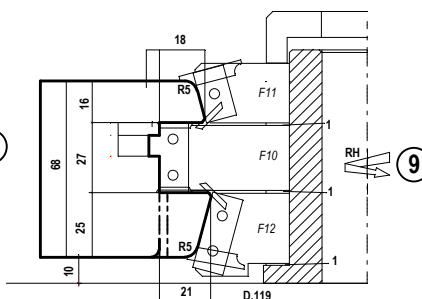

TRAVERSI AGGIUNTI PORTA-FINESTRA
ADDITIONAL WINDOW RAILS

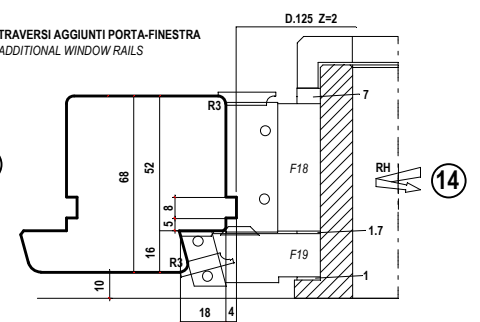

TANONI TRAVERSI ANTA
TENONING SASH RAILS

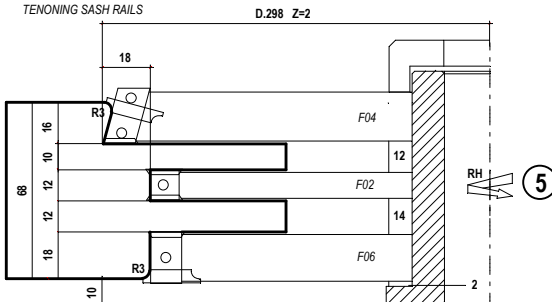

PROFILATURA TRAVERSO SUP. E MONTANTI TELAIO
PROFILING FRAME CROSS AND JAMBS

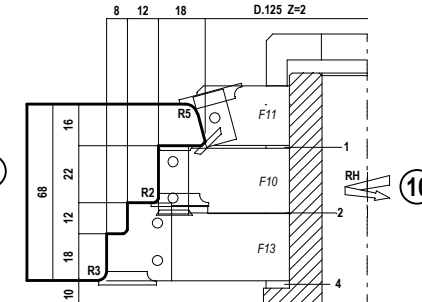

S 58 ARIA 4

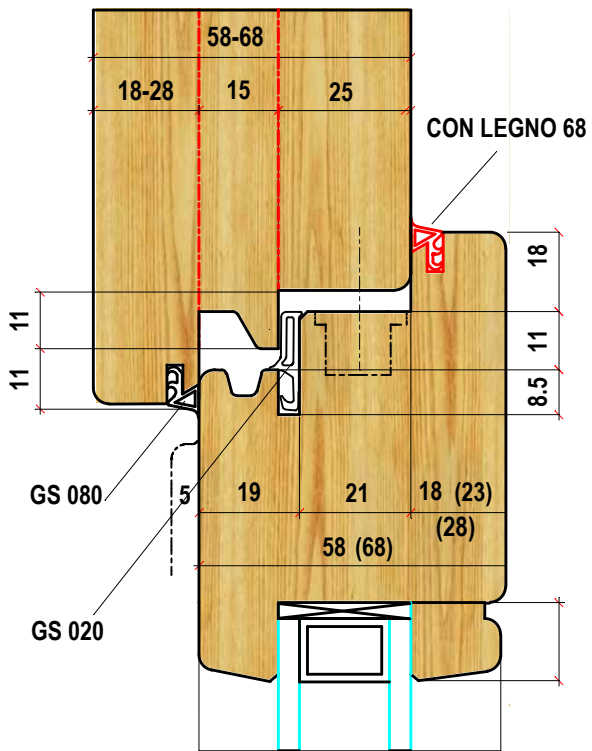

ARIA 4 2-3 GUARNIZIONI
TELAIO 58-68
ANTA 58-68
ESTERNO ANTA R3-5
SPIGOLI INTERNI R1-1,5
ANGOLI INTERNI R1
FERRAMENTA INTERASSE 9
LISTELLO CON SCURETTO
CONTROSAGOMA SOGLIA ALLUMINIO

VARIANTI
TUTTO LEGNO
ALLUMINIO RICOPERTO
MONTANTINO CENTRALE

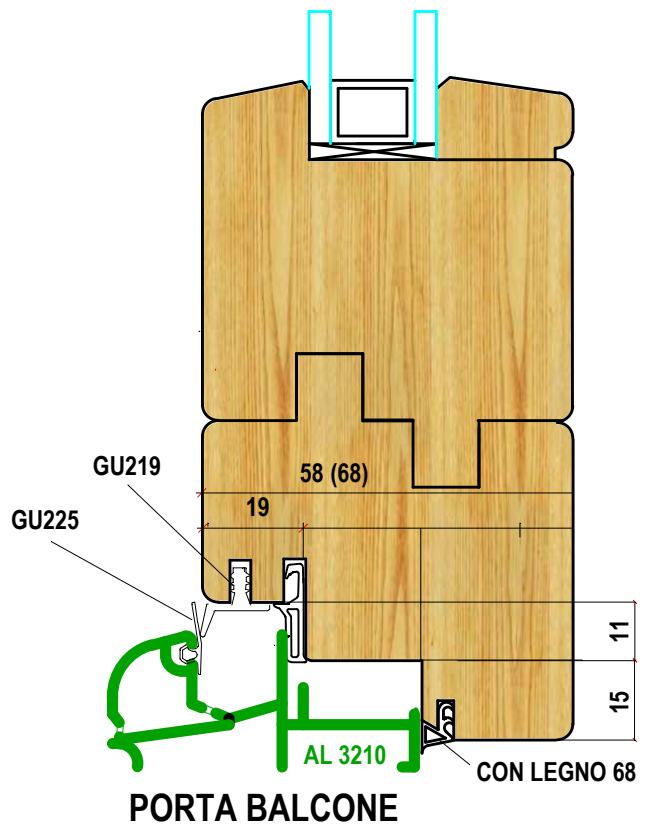
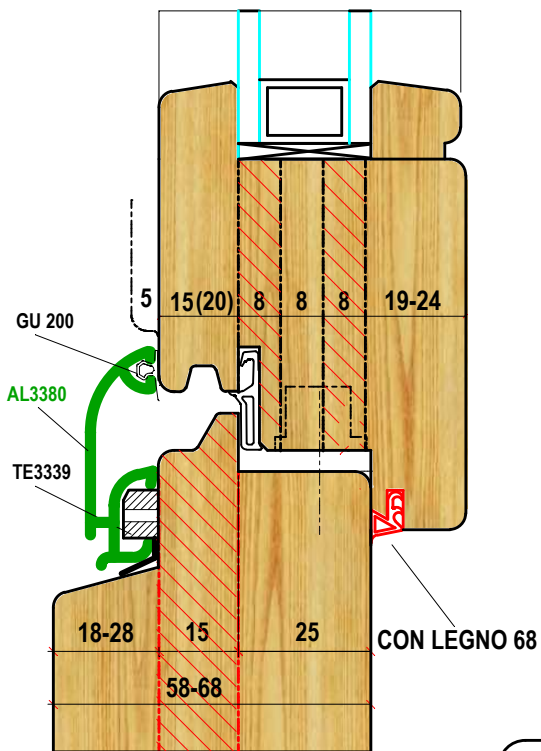

SEZIONE VERTICALE

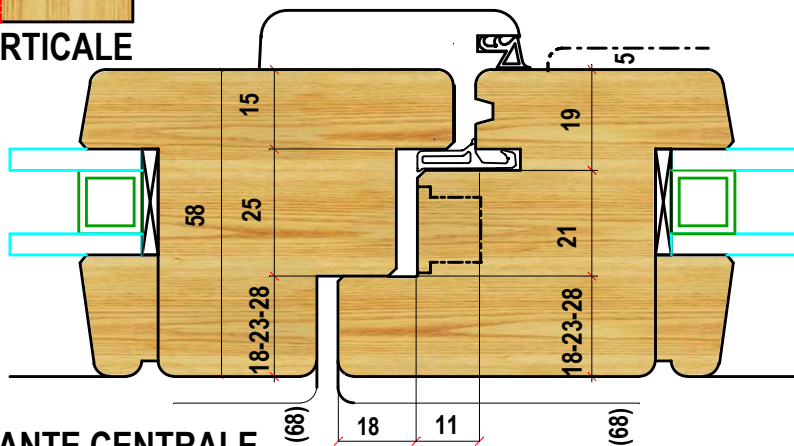

MONTANTE CENTRALE

S 58 ARIA 4

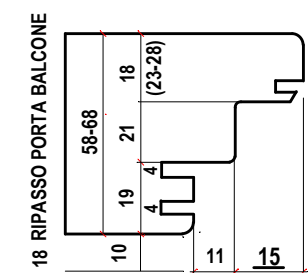
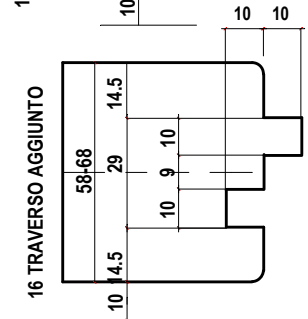
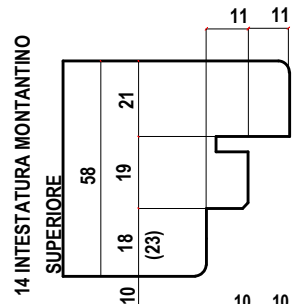
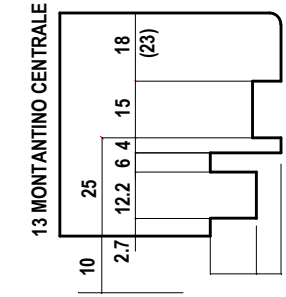
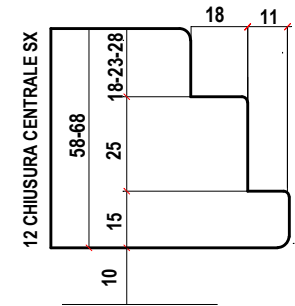
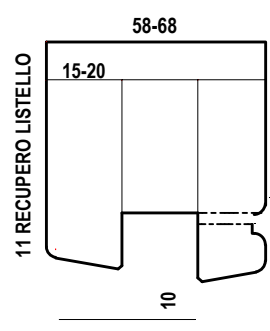
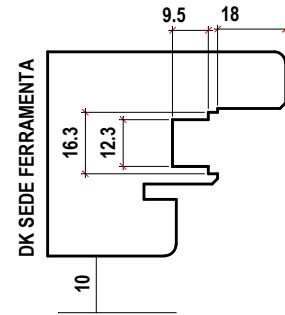
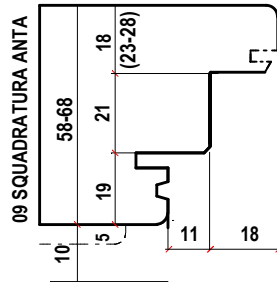
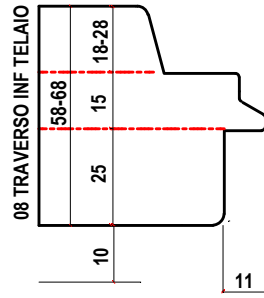
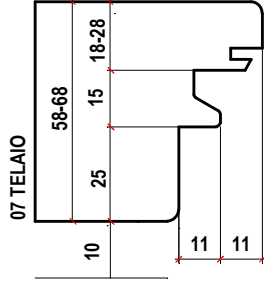
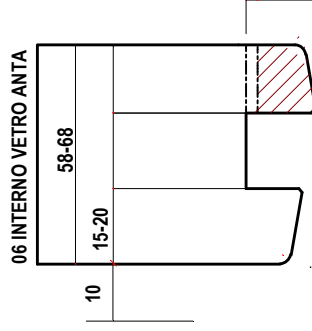
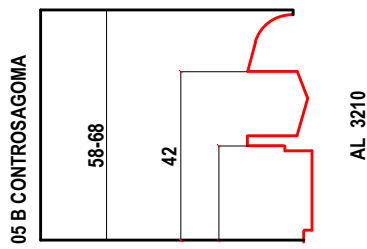
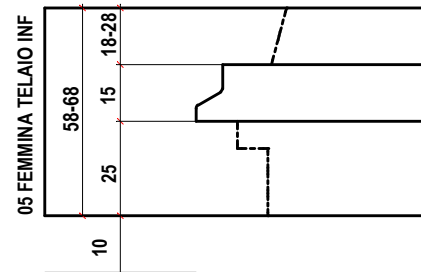
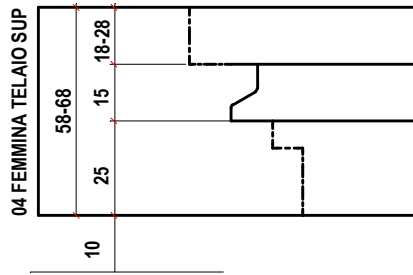
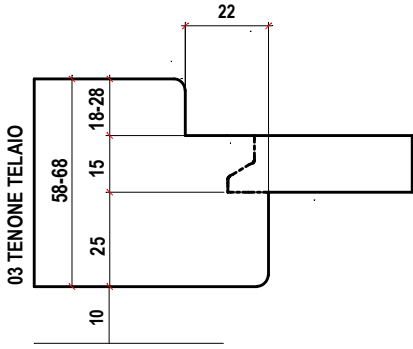
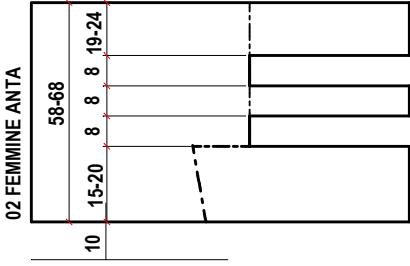
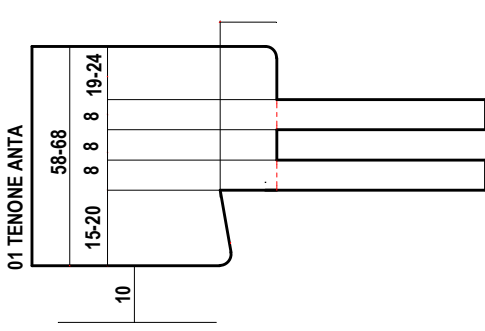

S 58 ARIA 12

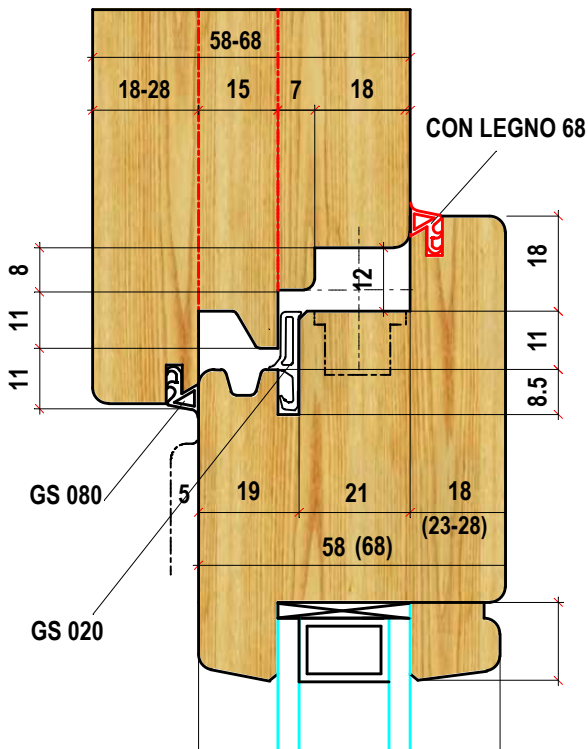

ARIA 12 2-3 GUARNIZIONI

TELAIO 58-68

ANTA 58-68

ESTERNO ANTA R3-5

SPIGOLI INTERNI R1-1.5

FERRAMENTA INTERASSE 9

LISTELLO CON SCURETTO

CONTROSAGOMA SOGLIA ALLUMINIO

VARIANTI

TUTTO LEGNO

ALLUMINIO RICOPERTO

MONTANTINO CENTRALE

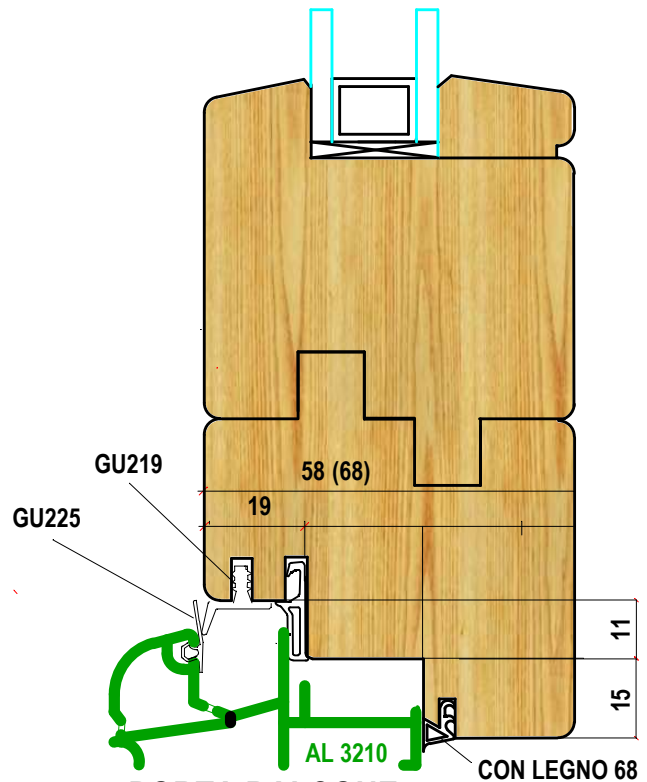
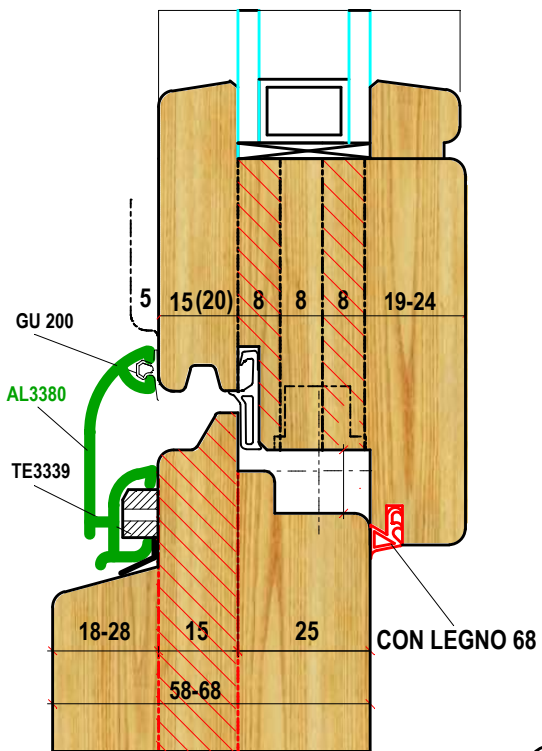

SEZIONE VERTICALE

PORTA BALCONE

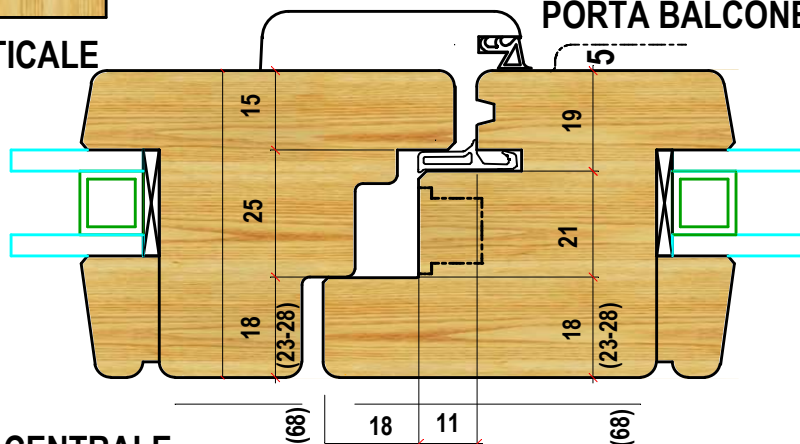

MONTANTE CENTRALE

S 58 ARIA 12

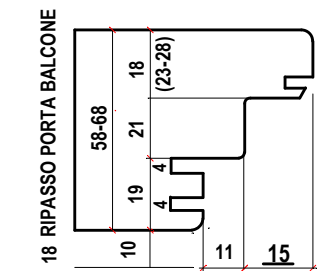
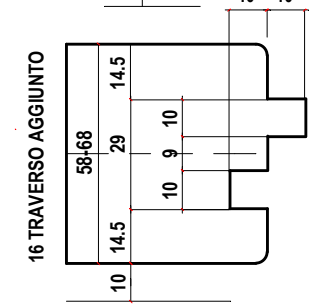
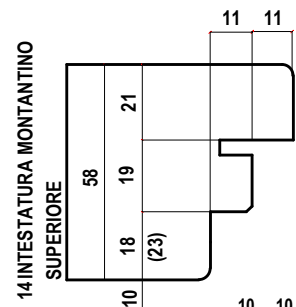
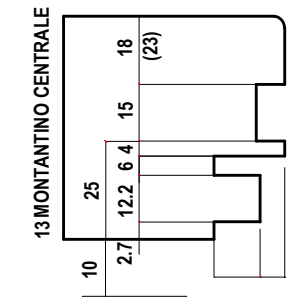
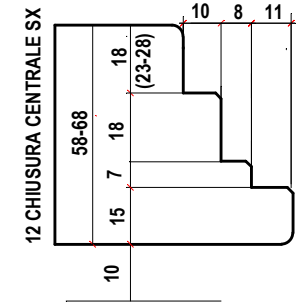
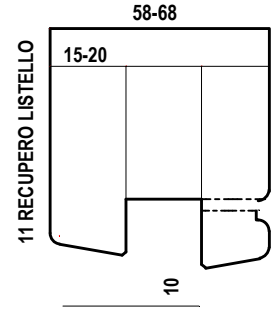
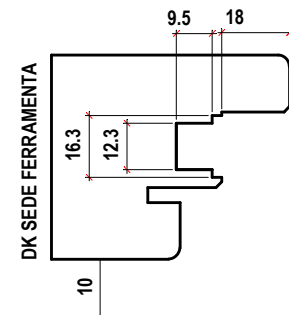
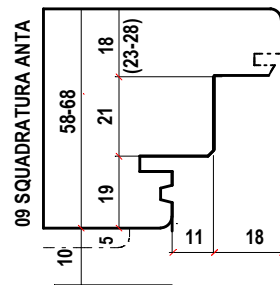
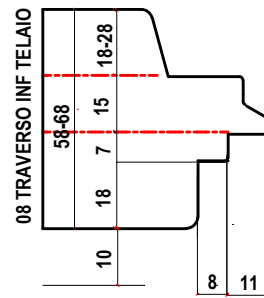
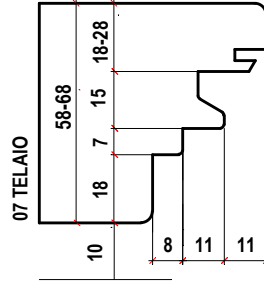
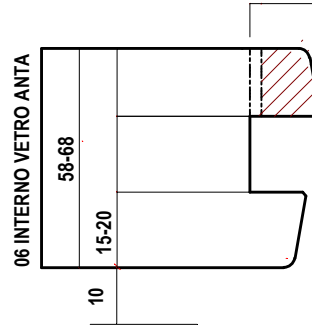
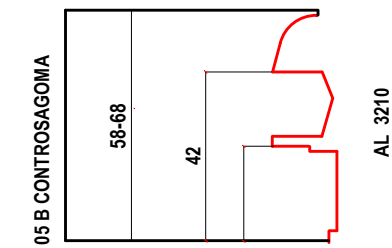
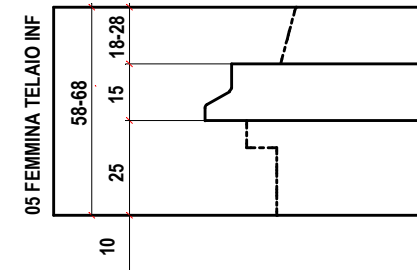
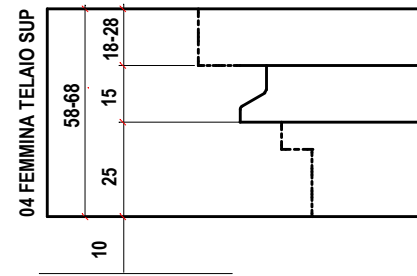
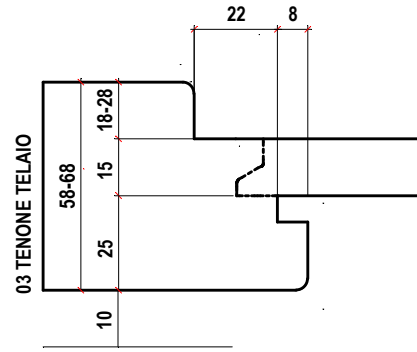
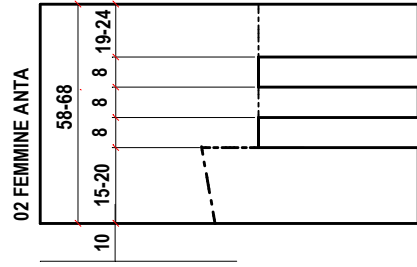
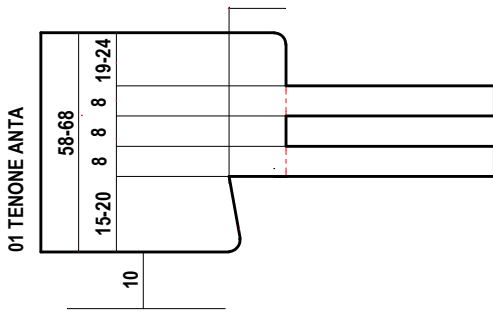

S68 ARIA 4

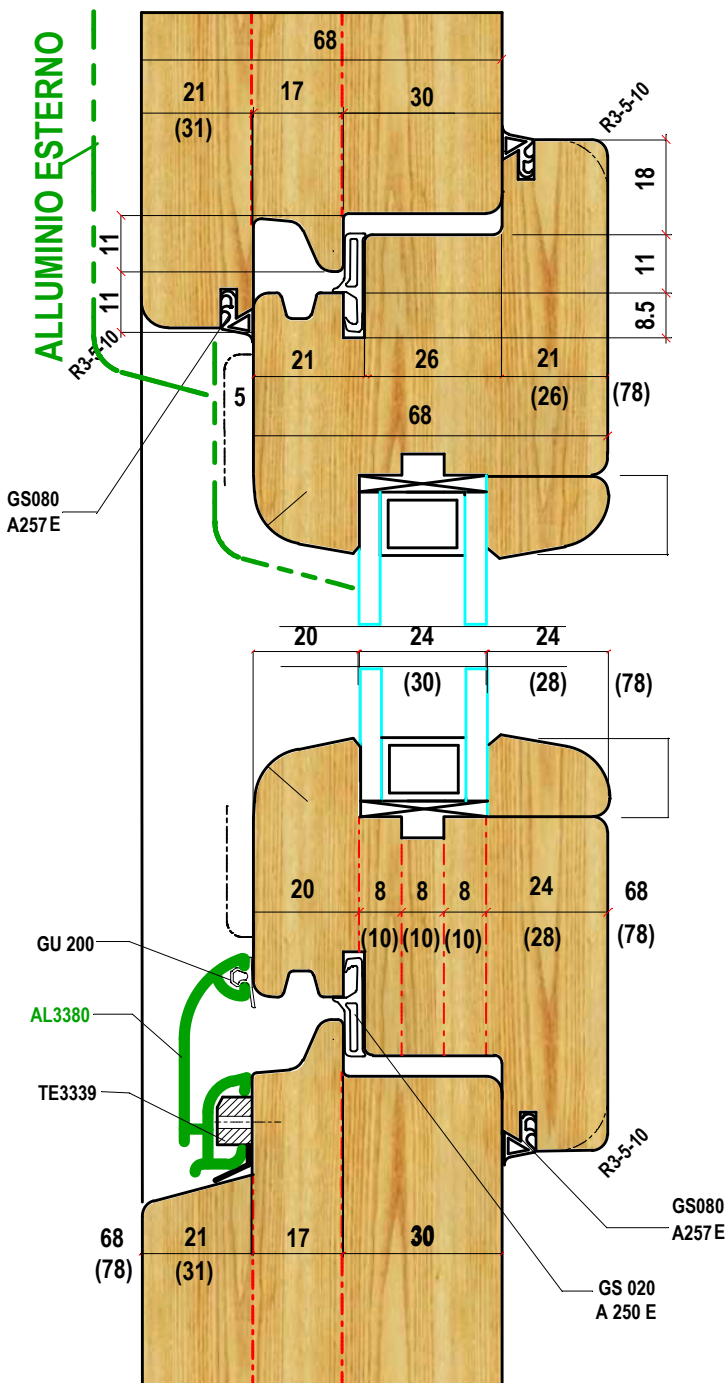

SEZIONE VERTICALE

ARIA 4 3 GUARNIZIONI

TELAIO 68-78

ANTA 68-78

ESTERNO ANTA R3-5-10

SPIGOLATORI INTERNI R1-1.5

ANGOLI INTERNI R1

FERRAMENTA INTERASSE 13

LISTELLO CON/SENZA SCURETTO

CONTROSAGOMA SOGLIA ALLUMINIO

VARIANTI OPTIONAL

TUTTO LEGNO

ALLUMINIO RICOPERTO LEGNO

MONTANTINO CENTRALE

ANTA FINO SPESSORE 92mm

LEGNO ALLUMINIO

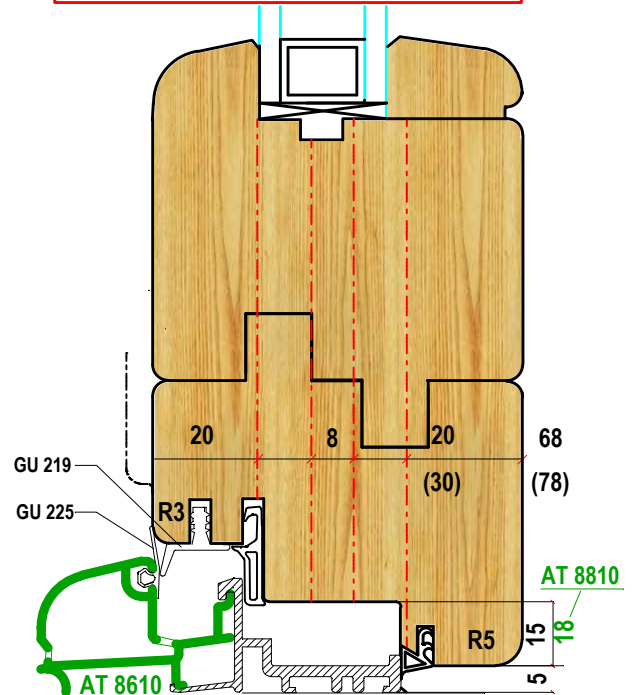

PORTA BALCONE

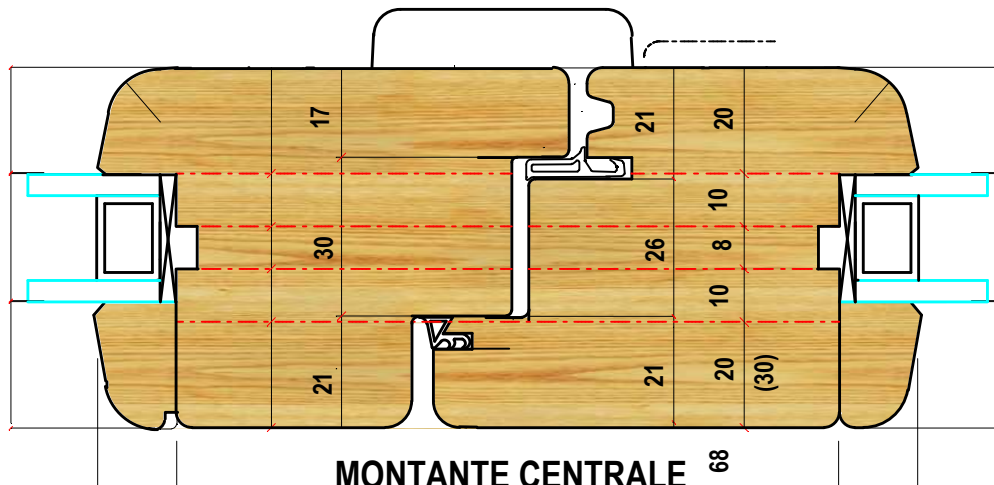

MONTANTE CENTRALE

S 68 ARIA 4

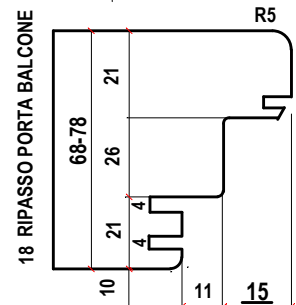
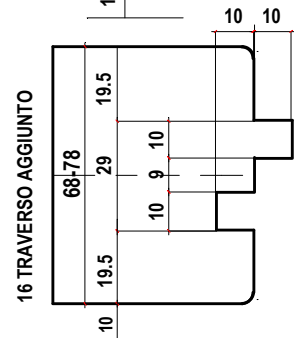
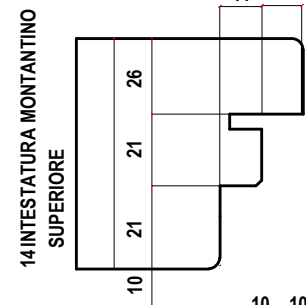
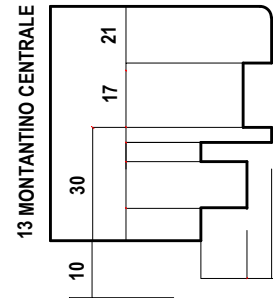
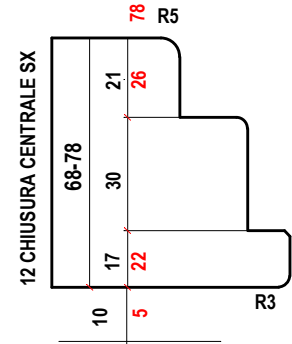
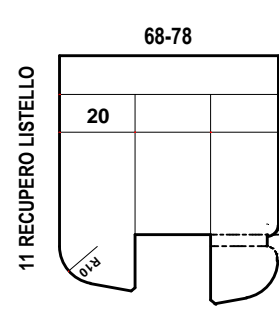
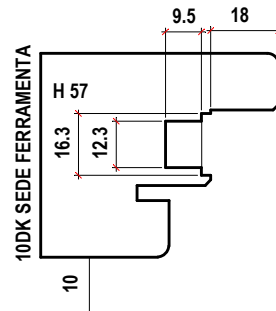
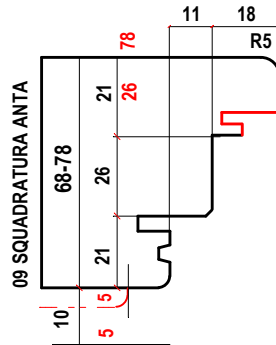
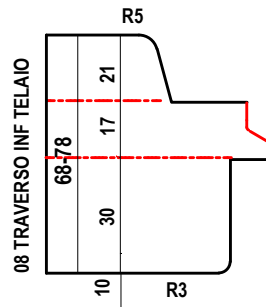
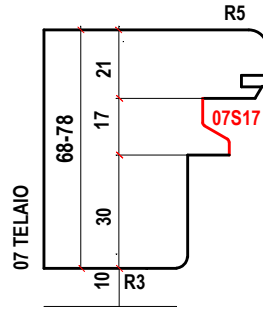
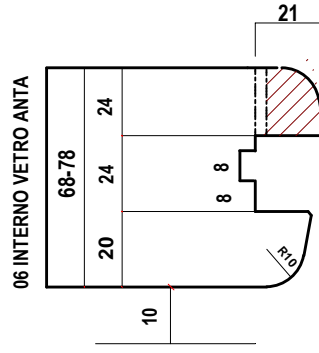
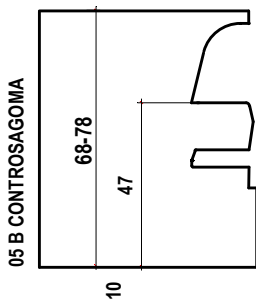
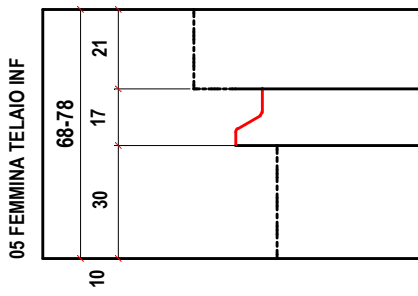
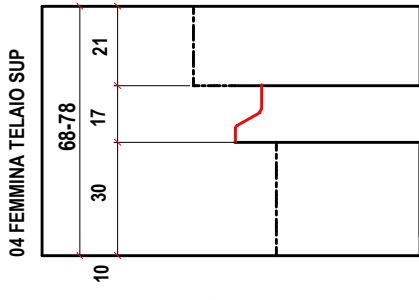
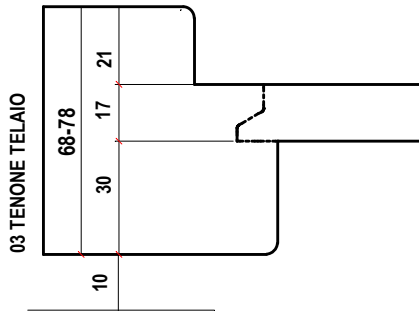
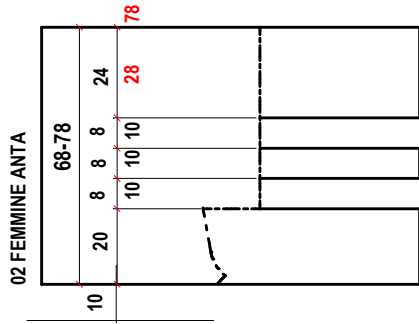
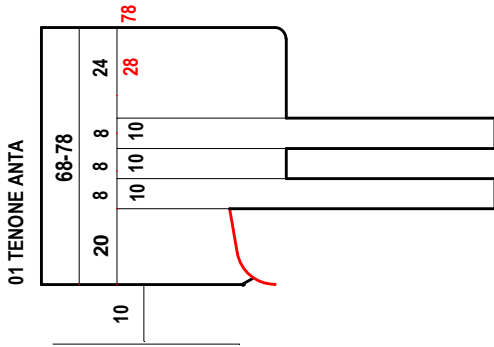

OPTIONAL
 ANTA FINO SPESSORE 92 mm
 LEGNO ALLUMINIO CON GLI STESSI GRUPPI

S 68 ARIA 12

ARIA 12 3 GUARNIZIONI

TELAIO 68-78

ANTA 68-78

ESTERNO ANTA R3-5-10

SPIGOLI INTERNI R1-1.5

ANGOLI INTERNI R1

FERRAMENTA INTERASSE 13

LISTELLO CON/SENZA SCURETTO

CONTROSAGOMA SOGLIA ALLUMINIO

VARIANTI

TUTTO LEGNO

ALLUMINIO RICOPERTO LEGNO

MONTANTINO CENTRALE

ANTA FINO SPESSORE 92 mm

LEGNO ALLUMINIO

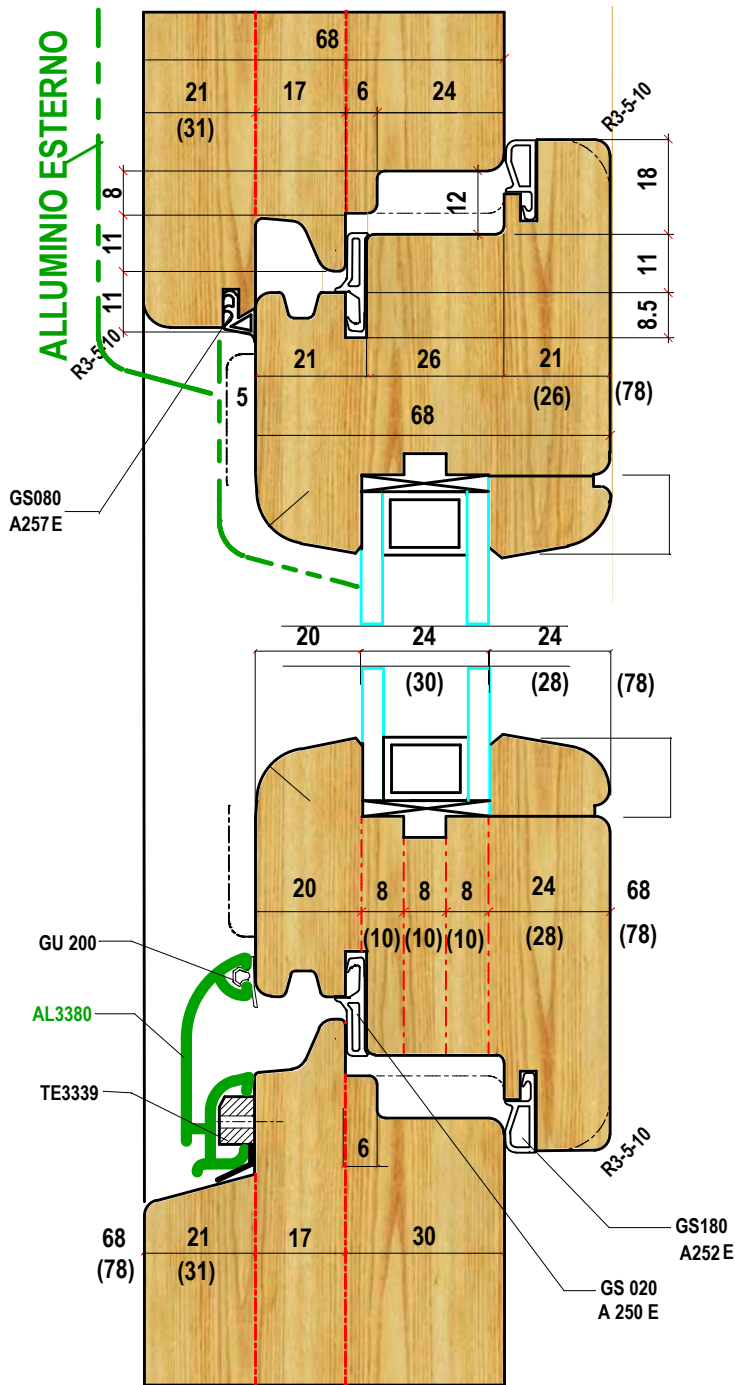

SEZIONE VERTICALE

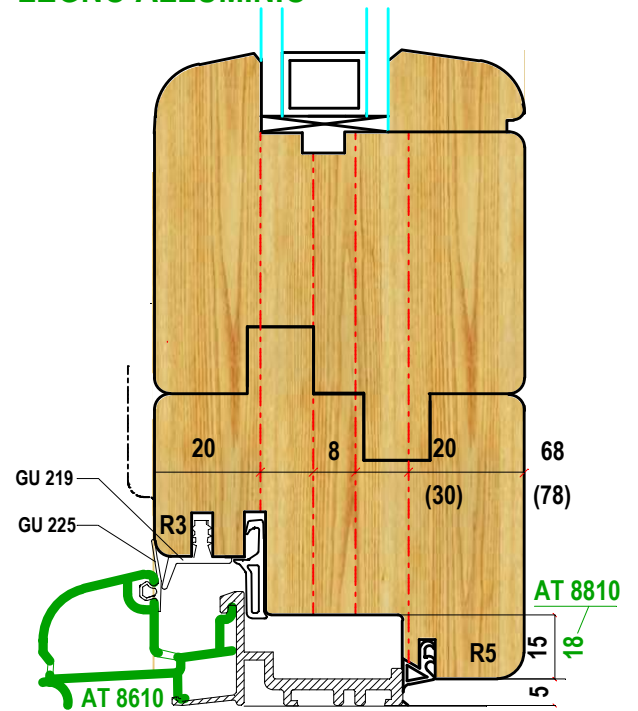

PORTA BALCONE

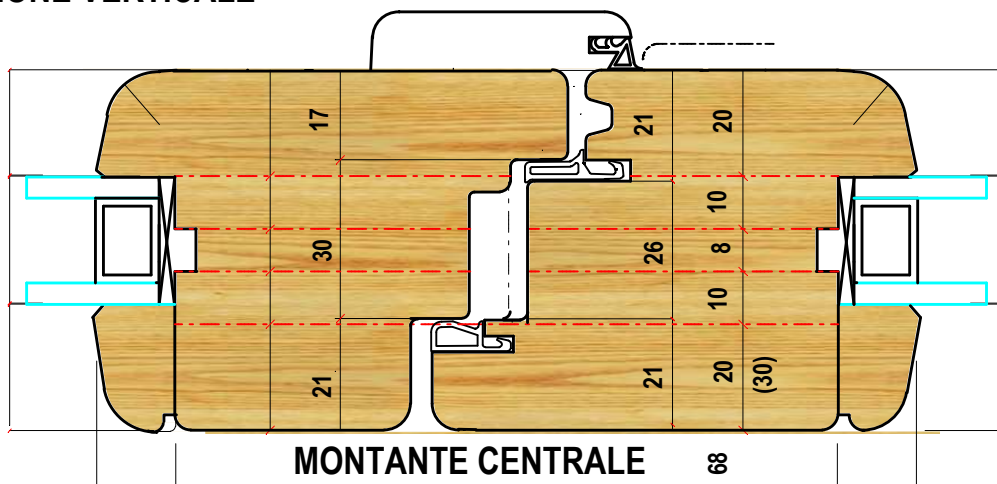

MONTANTE CENTRALE

S 68 ARIA 12

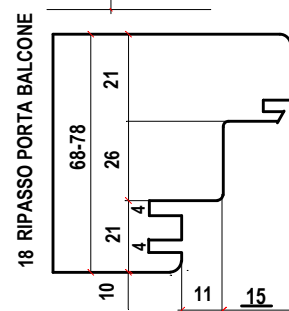
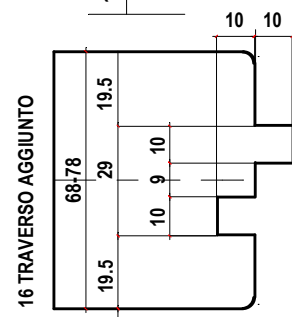
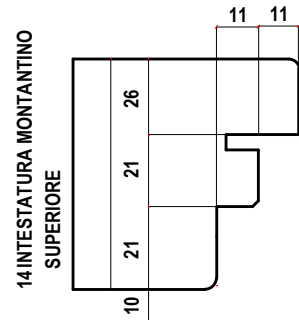
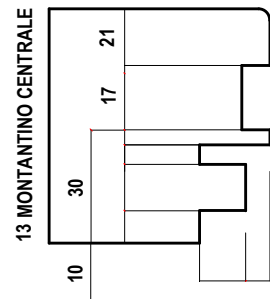
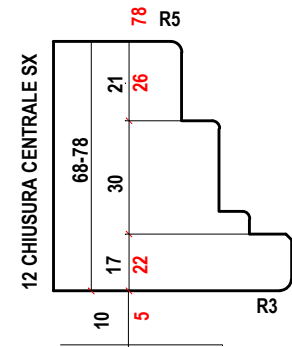
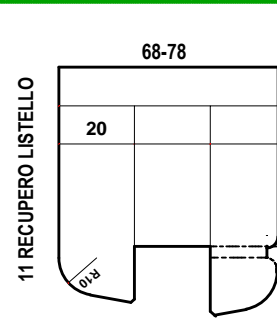
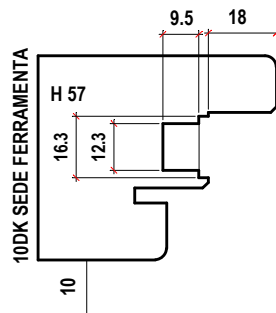
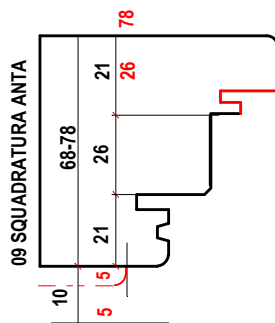
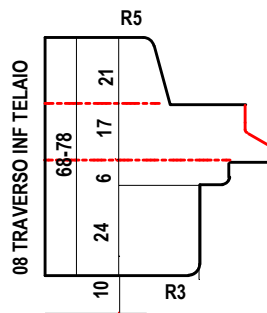
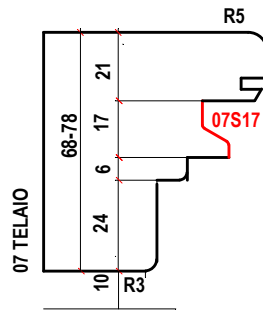
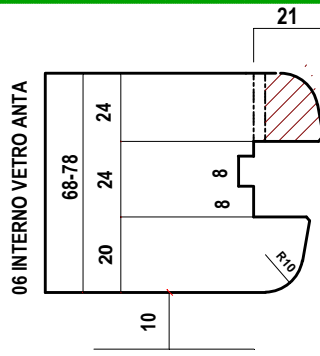
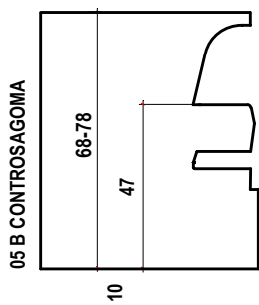
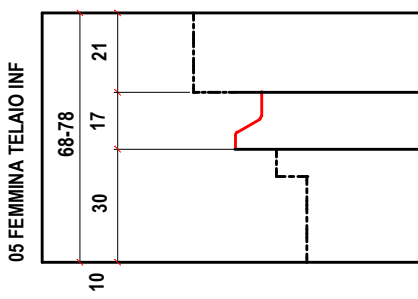
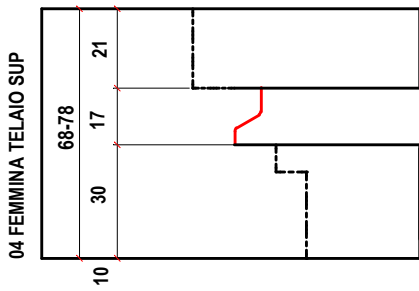
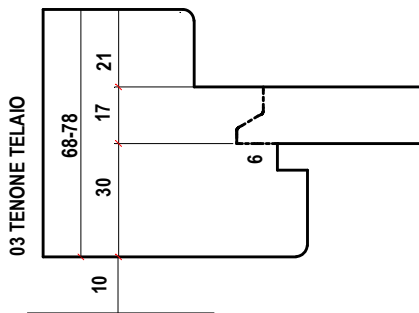
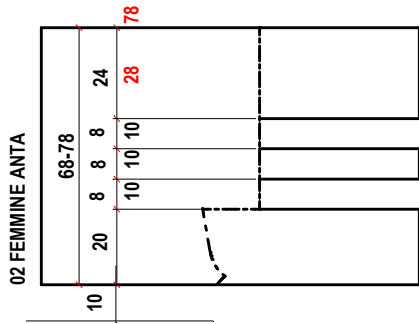
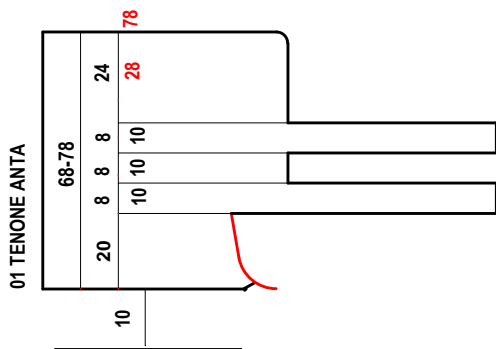

OPTIONAL
ANTA FINO SPESSORE 92 mm

LEGNO ALLUMINIO CON GLI STESSI GRUPPI

S78 ARIA 4

ARIA 4 3 GUARNIZIONI
ANTA e TELAIO 78 - 92 mm
VETRO SPESSORE 33-52 mm
ESTERNO ANTA R3-R5
SPIGOLI INTERNI R1.5
ANGOLI INTERNI R1
FERRAMENTA INTERASSE 13

ANCHE LEGNO-ALLUMINIO

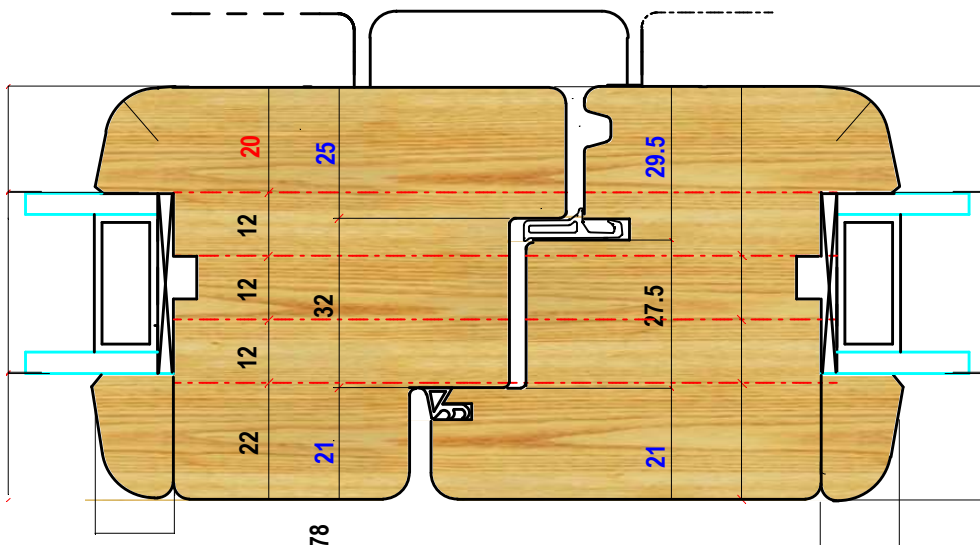
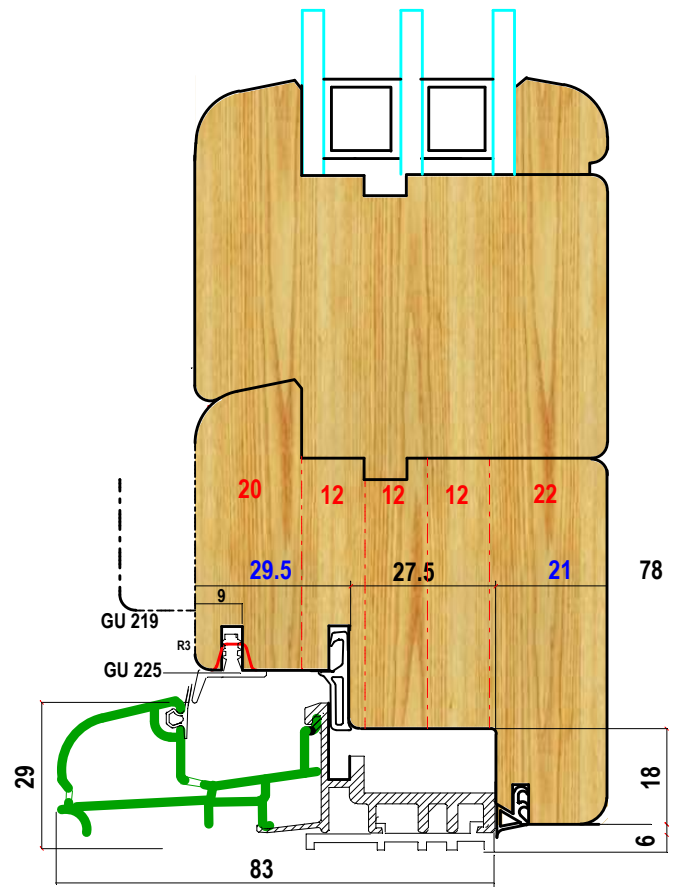
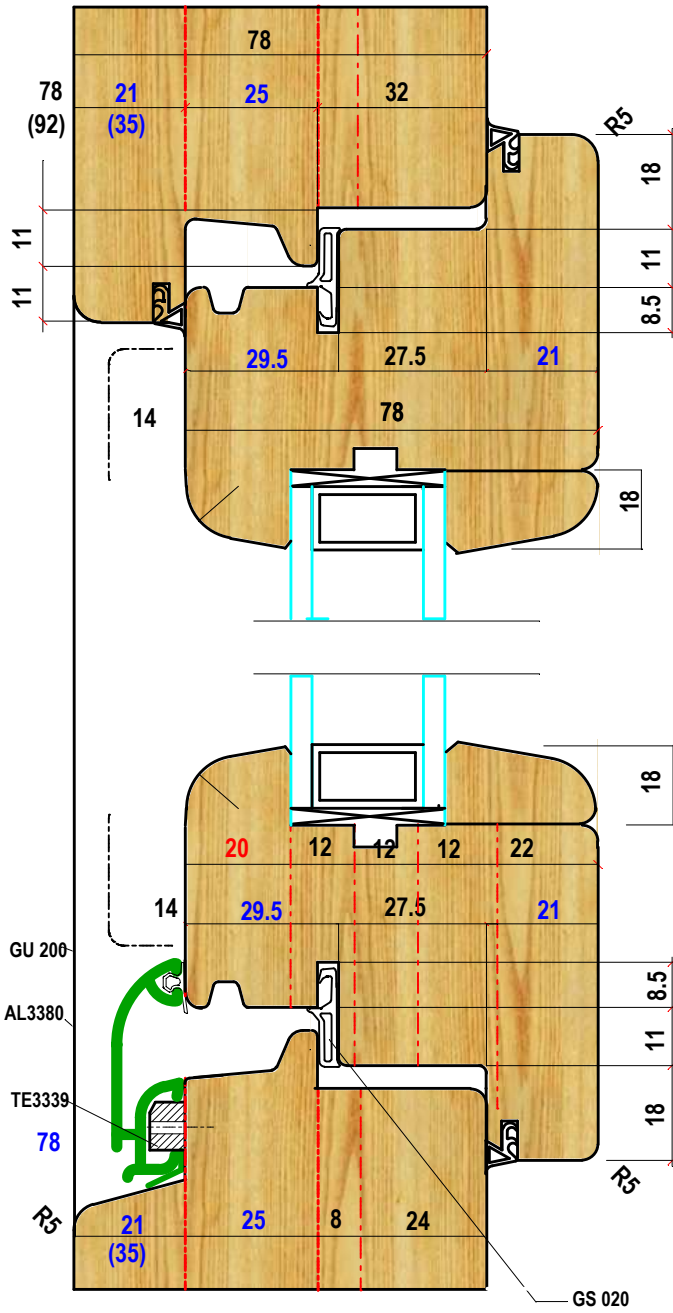

S78 ARIA 12

ARIA 12 3 GUARNIZIONI
ANTA E TELAIO 78-92 mm
VETRO SPESSORE 33-52 mm
ESTERNO ANTA R3-R5
SPIGOLI INTERNI R1.5
ANGOLI INTERNI R1
FERRAMENTA INTERASSE 13

ANCHE LEGNO-ALLUMINIO

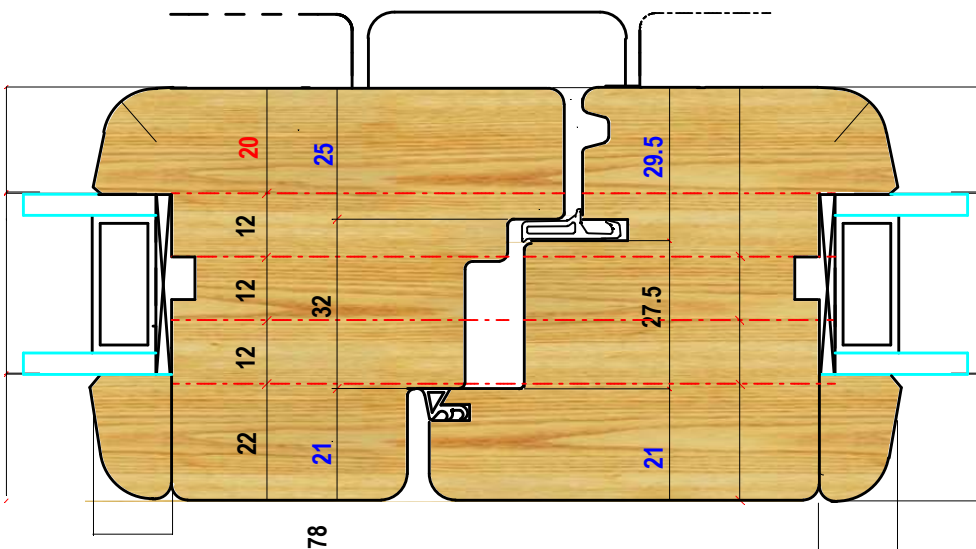
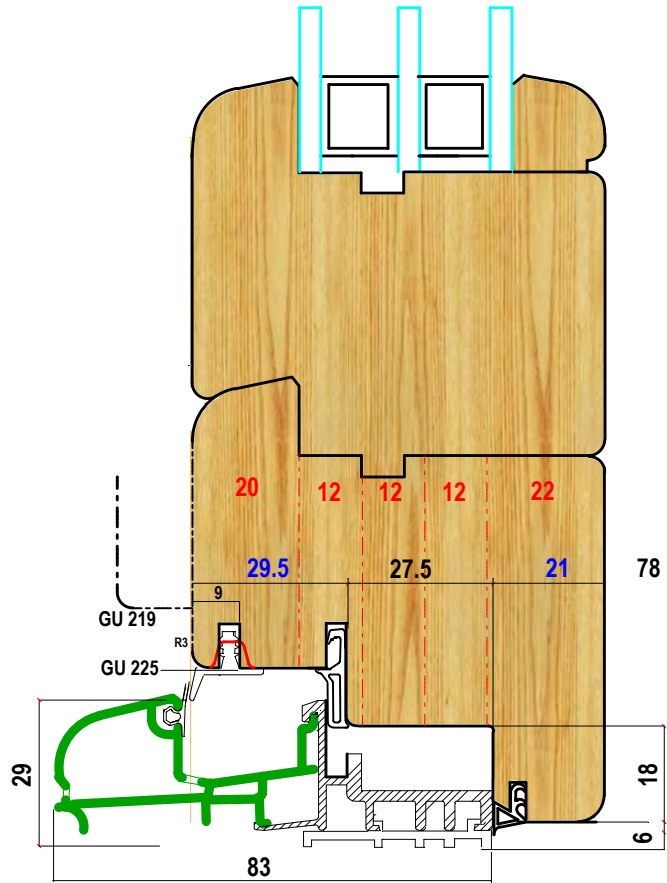
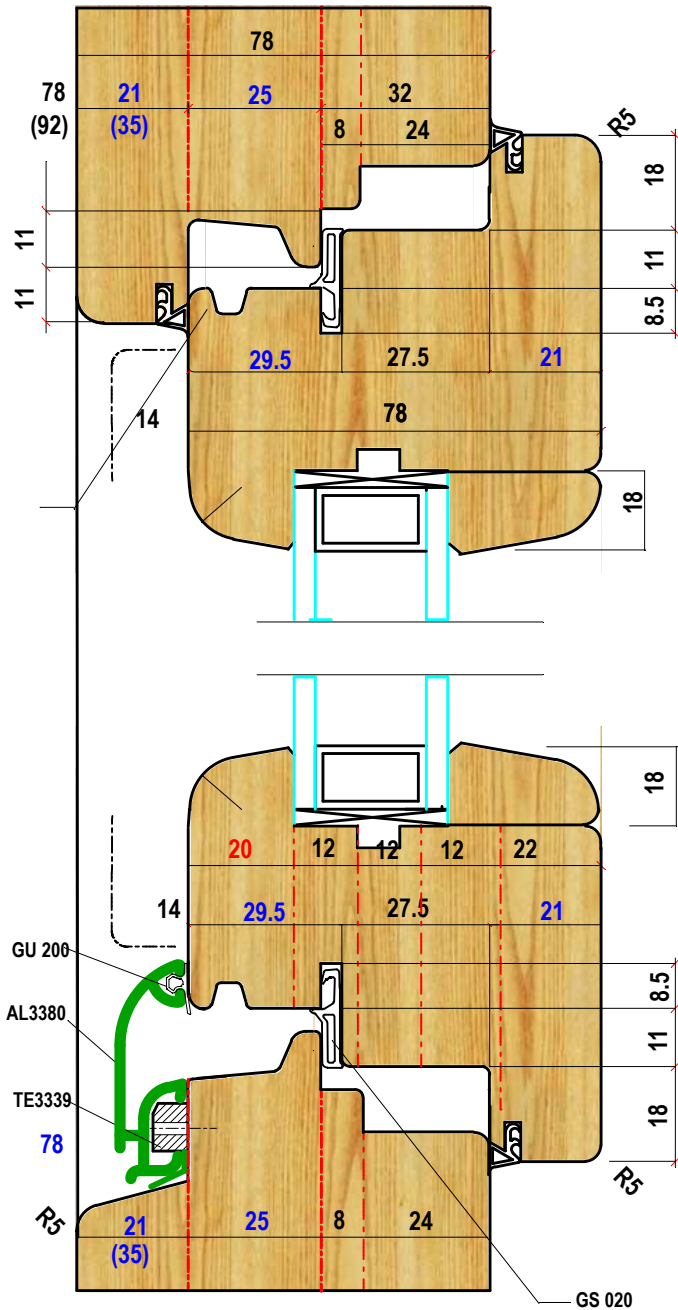

S78D ARIA4

**ARIA 4 3 GUARNIZIONI
ANTA e TELAIO 78-92 mm
CON DOPPIO TENONE**

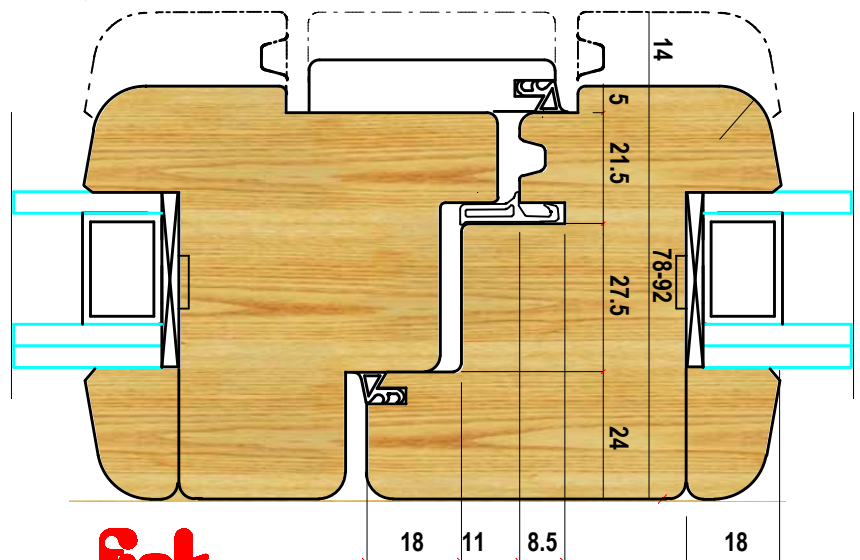
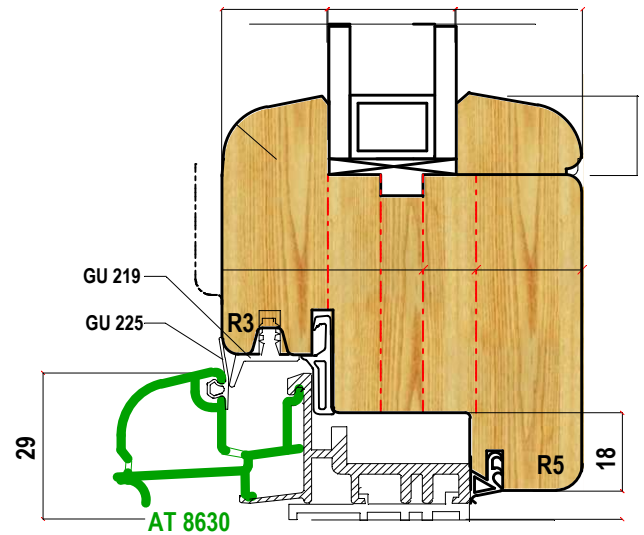
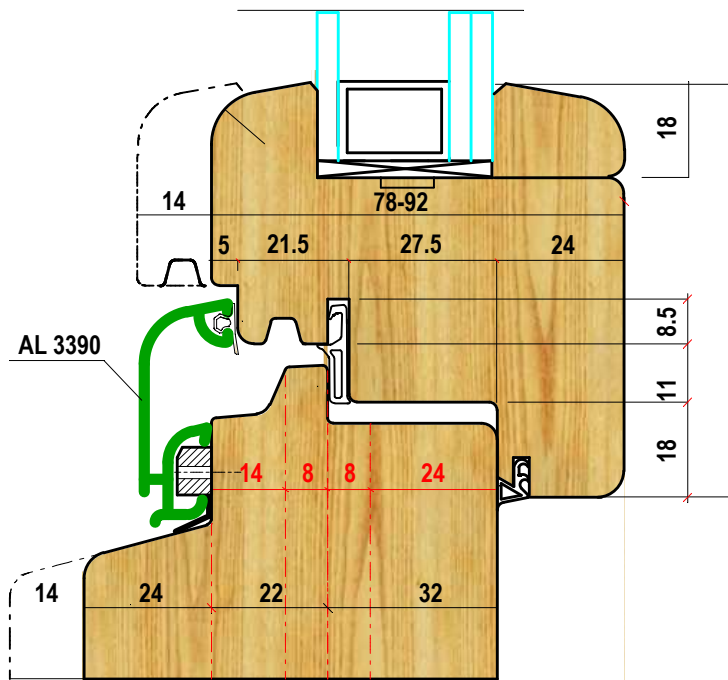
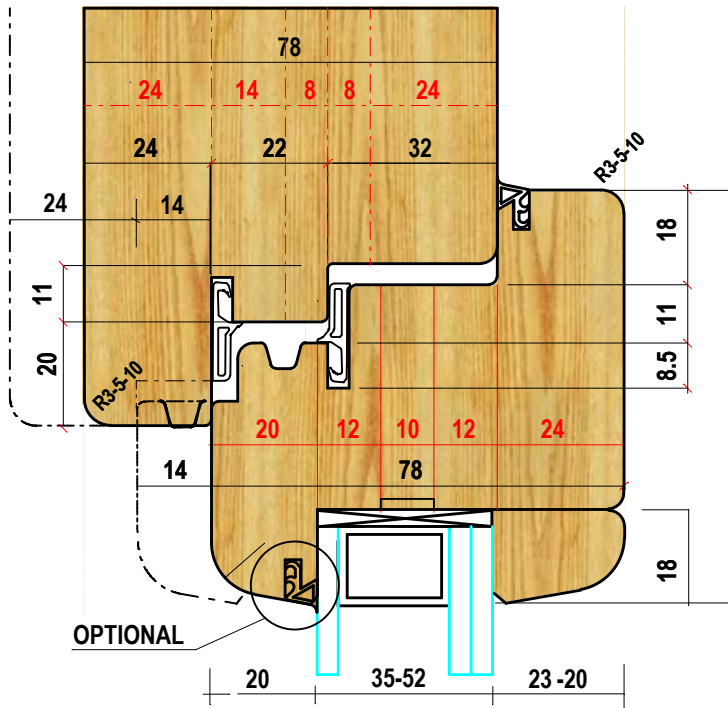

S78D ARIA12

ARIA 12 3GUARNIZIONI
 ANTA e TELAIO 78-92 mm
 CON DOPPIO TENONE

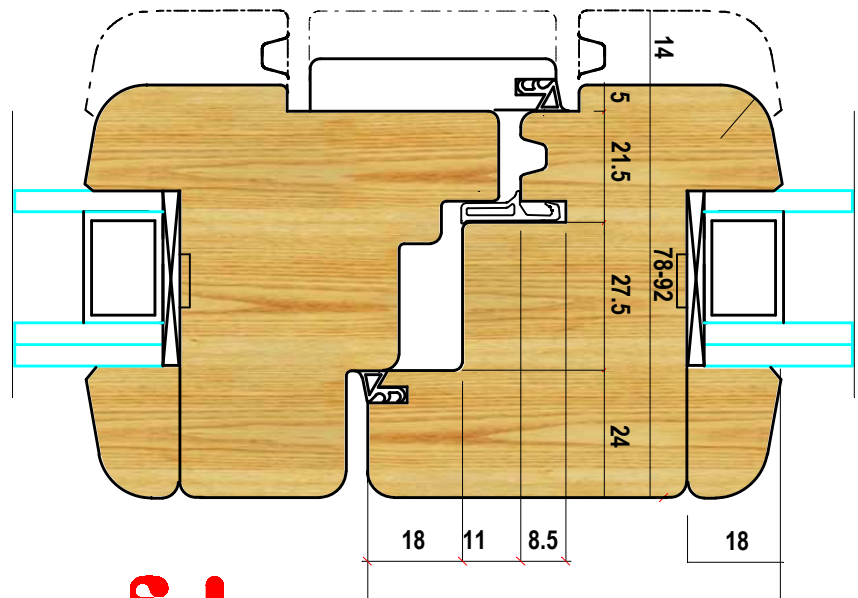
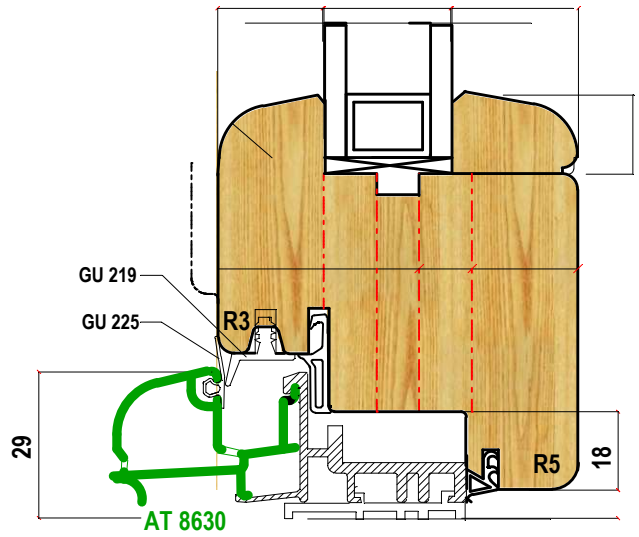
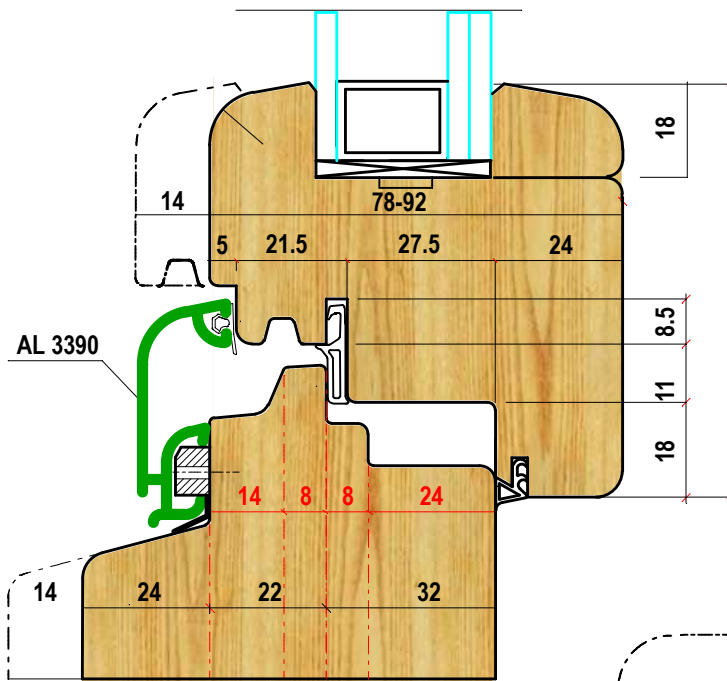
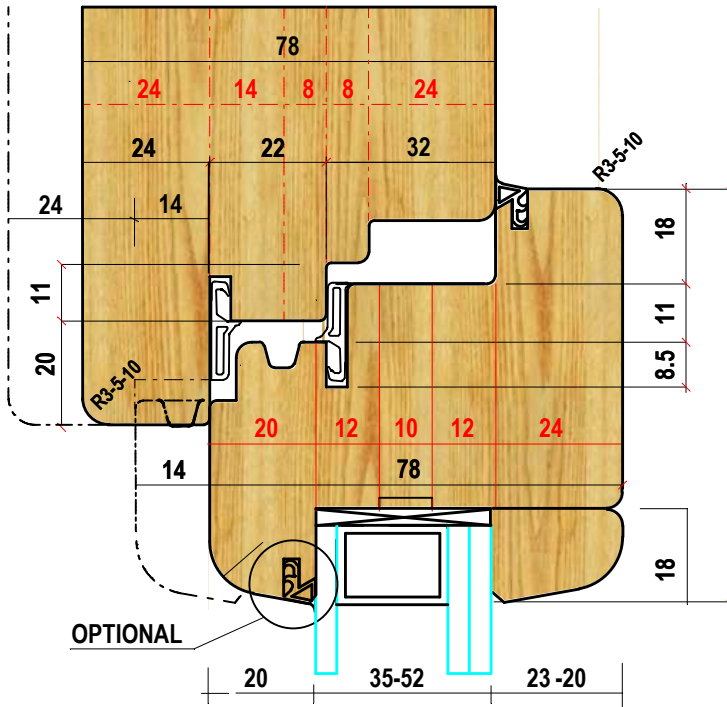

S90 ARIA 12

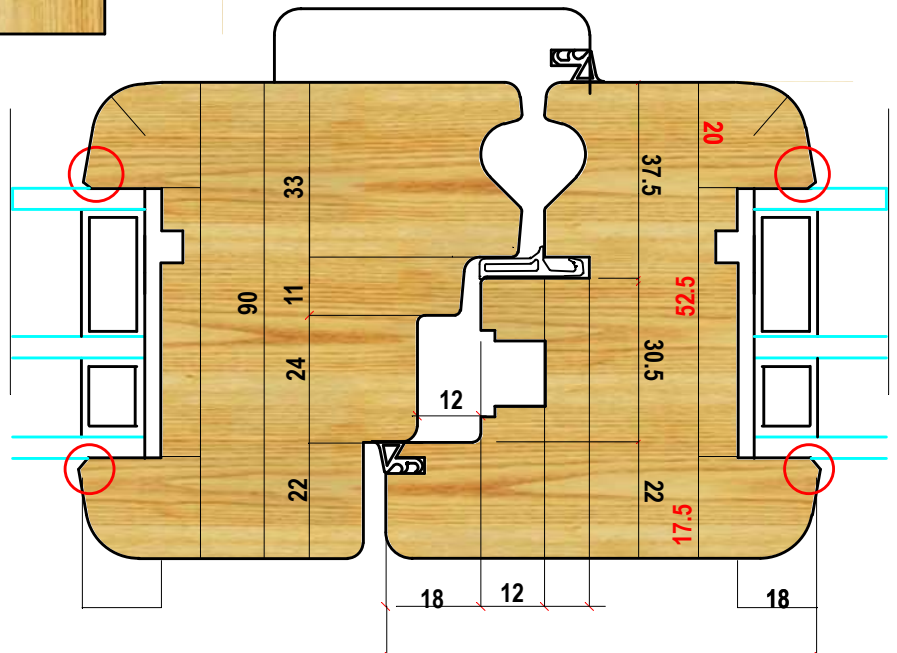
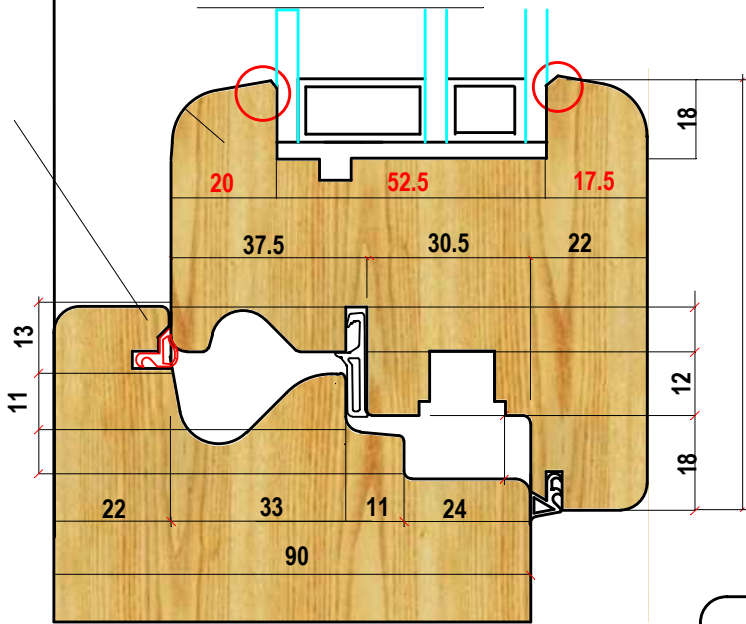
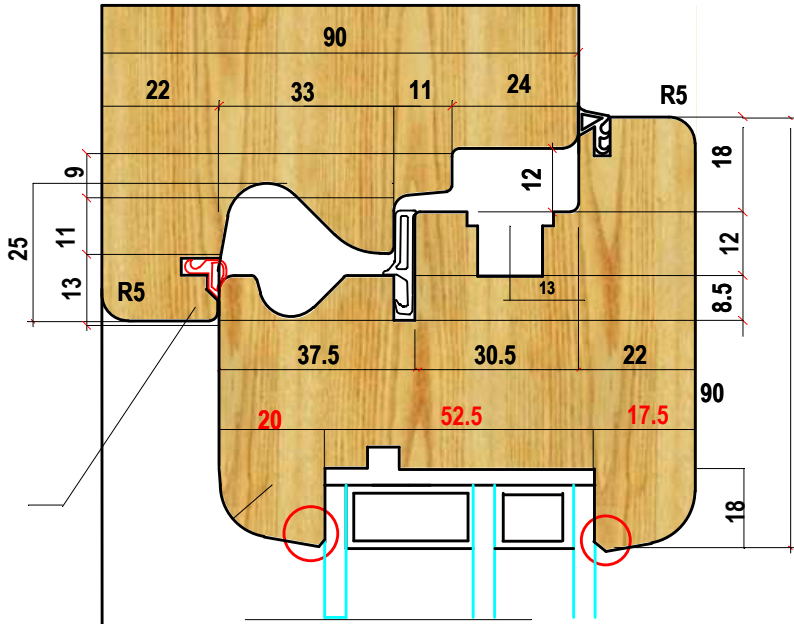

S90 ARIA 12

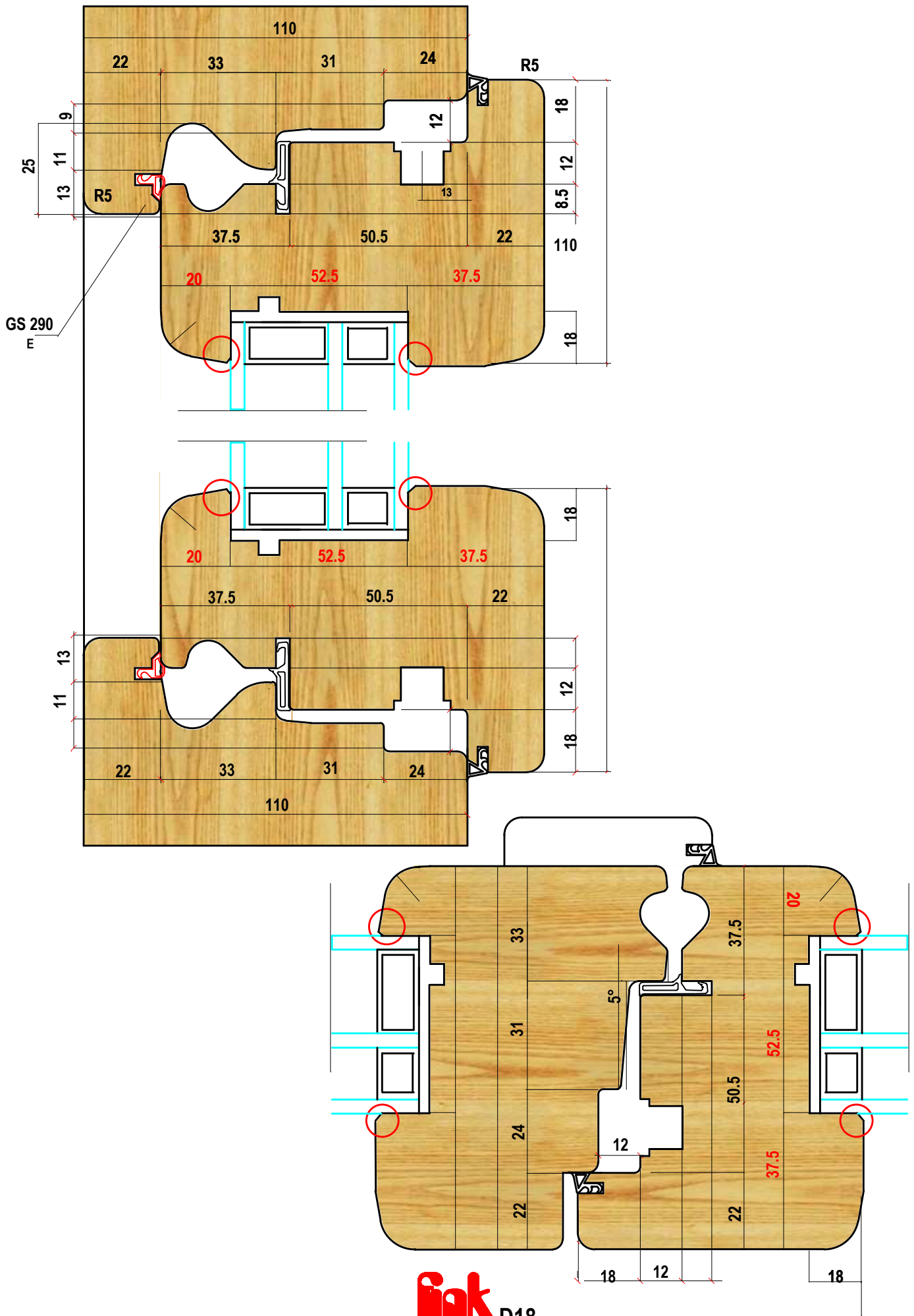

LA 66 ARIA 12

ARIA 12 ARIA 4
TELAIO 61
ANTA 66-72
ESTERNO ANTA R5-10
SPIGOLI INTERNI R1-1.5
FERRAMENTA INTERASSE 9
SOGLIA PORTA BALCONE

VARIANTI
MONTANTINO CENTRALE

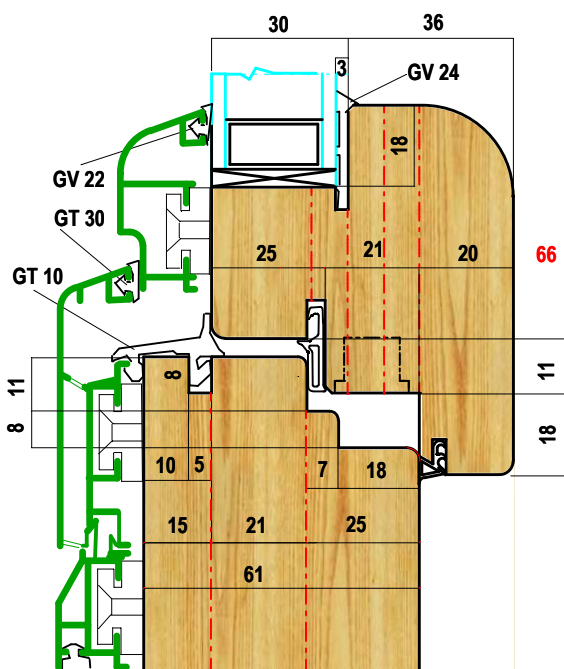
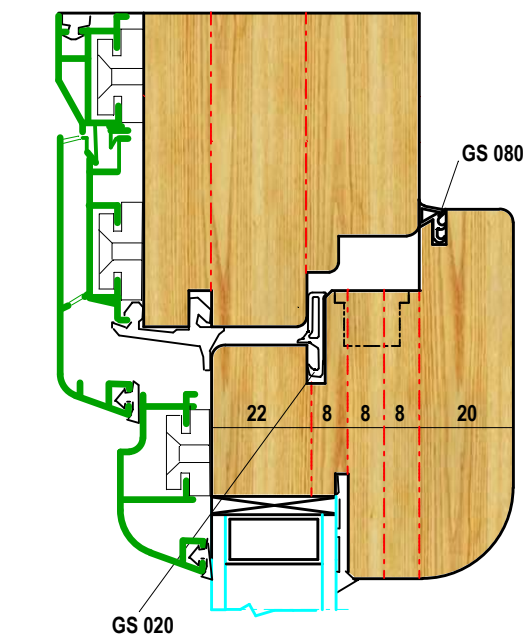

SEZIONE VERTICALE

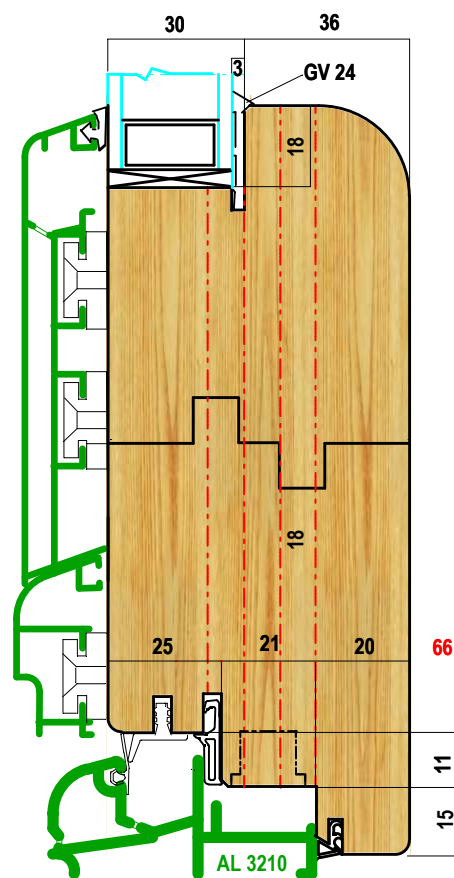

PORTA BALCONE

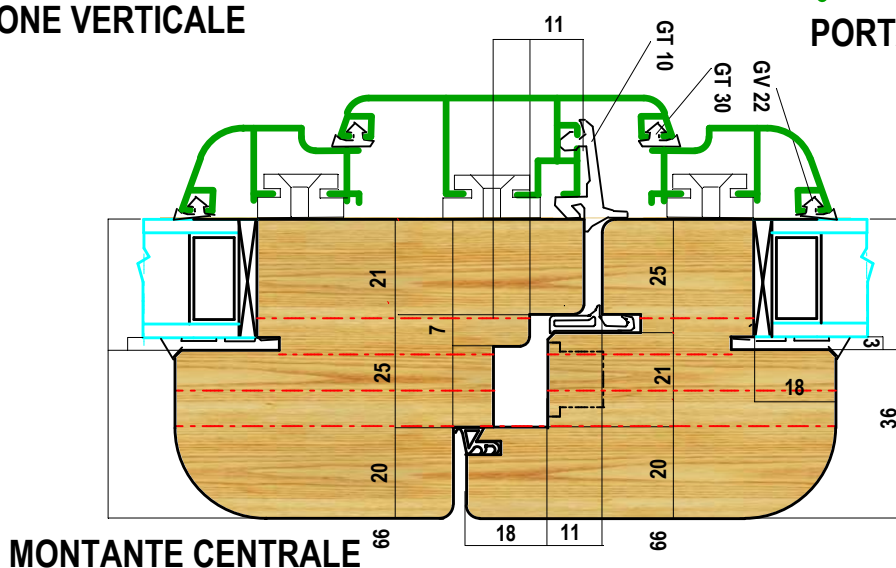

MONTANTE CENTRALE

LA 66 ARIA 12

05 B CONTROSAGOMA

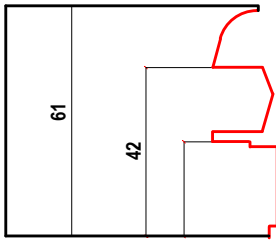

AL 3210

05 FEMMINA TELAIO INF

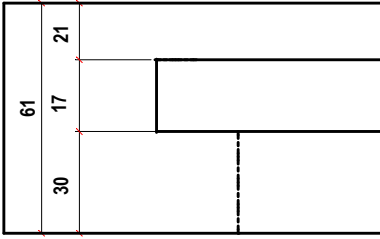

03 TENONE TELAIO

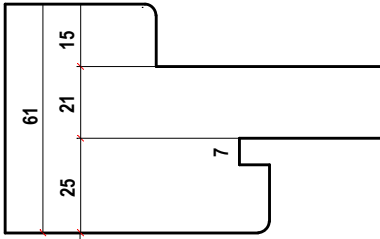

02 TENONI MONTANTI ANTA

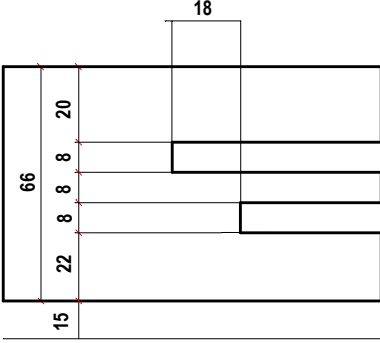

01 TENONI TRAVERSI ANTA

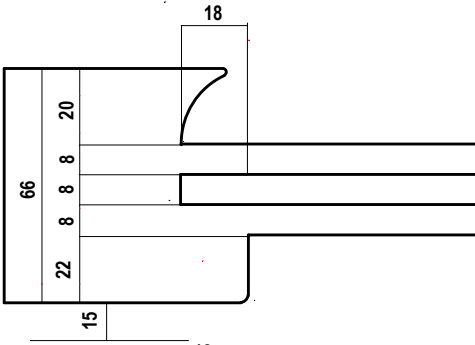

10DK SEDE FERRAMENTA

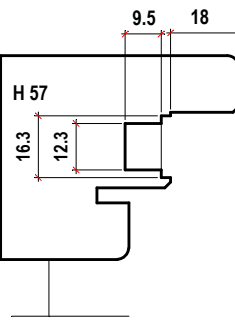

09 SQUADRATURA ANTA

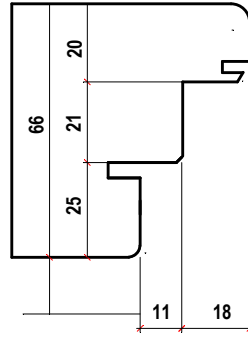

07 PROFILO TELAIO

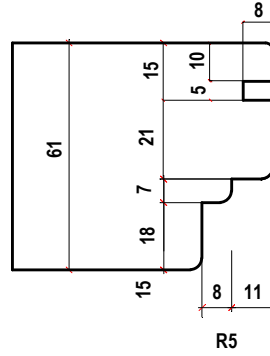

06 PROFILO INTERNO ANTA

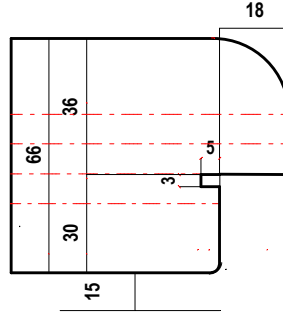

18 RIPASSO PORTA BALCONE

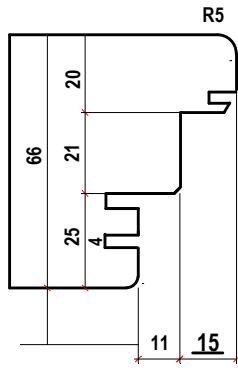

16 TRAVERSO AGGIUNTO

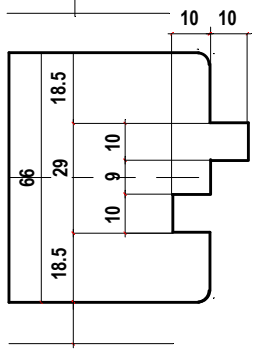

12 CHIUSURA CENTRALE SX

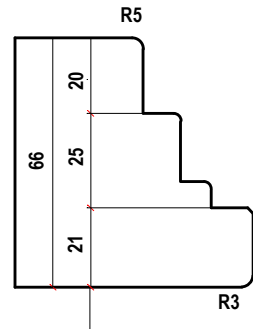

JV 68 EUROFALTZ

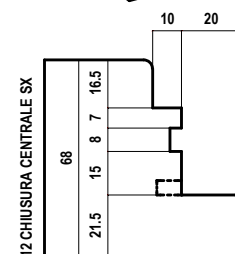
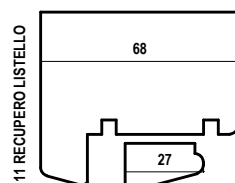
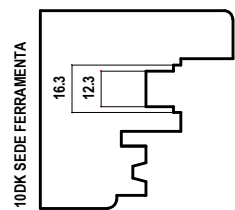
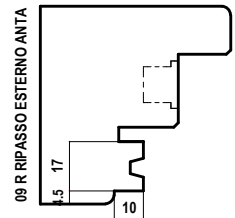
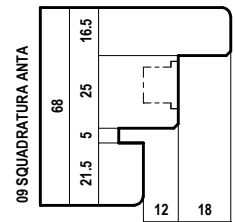
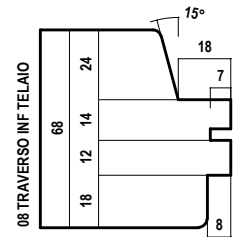
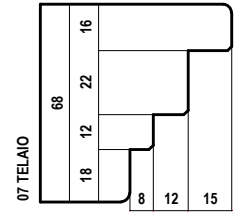
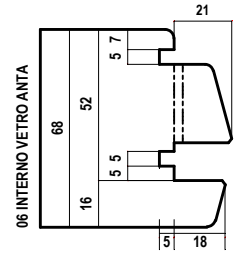
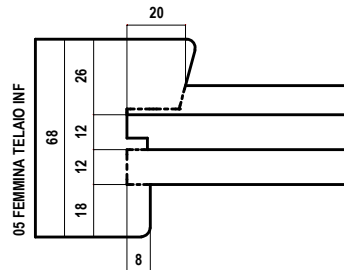
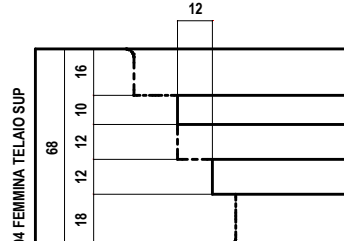
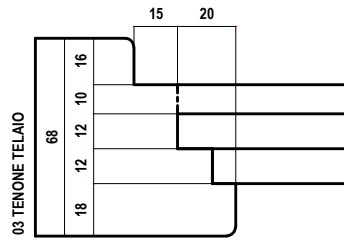
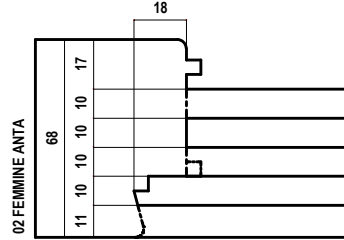
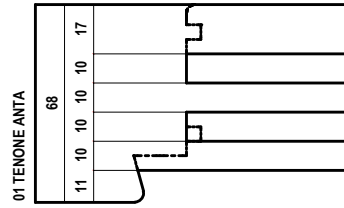
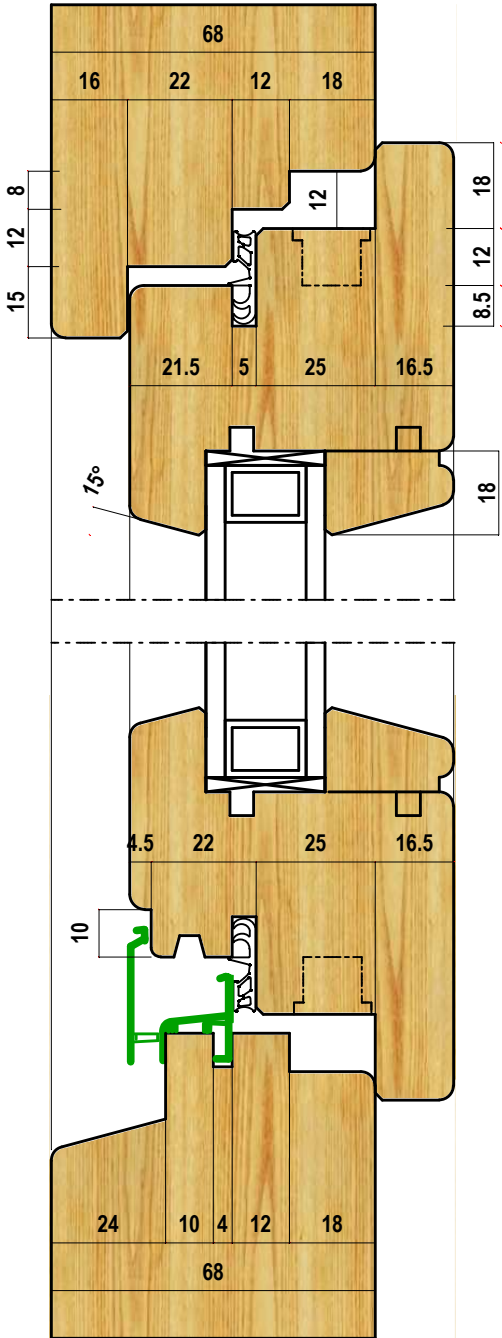

ARIA 12
TELAIO e ANTA 68-78 mm
ESTERNO ANTA R3-5
SPIGOLI INTERNI R1-1.5

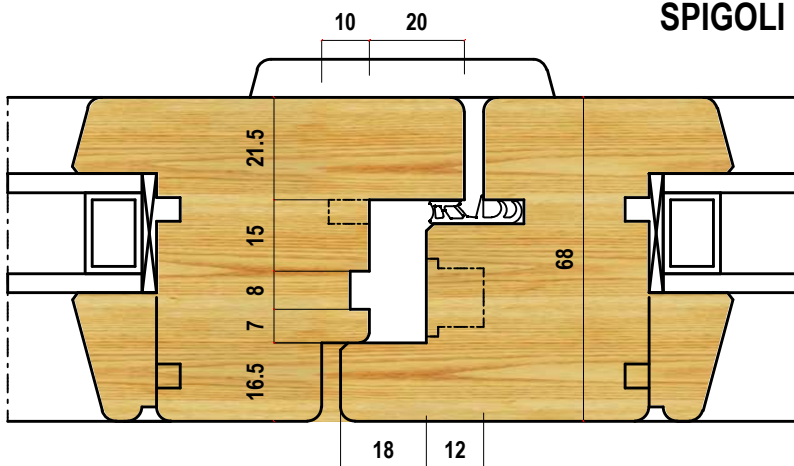

JV 68 EURONUT

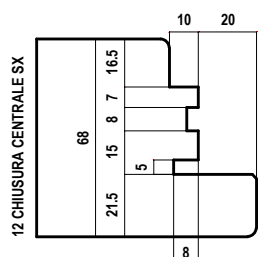
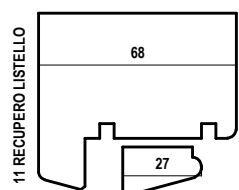
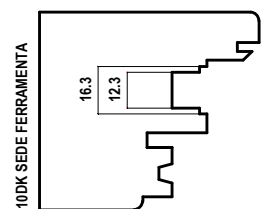
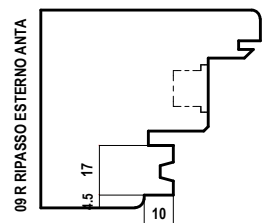
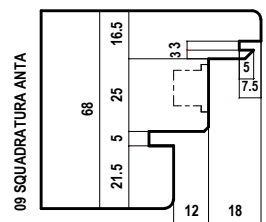
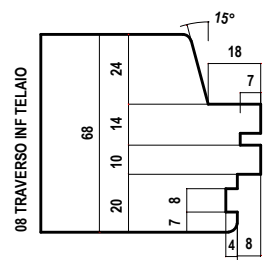
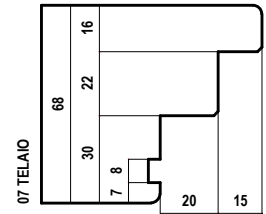
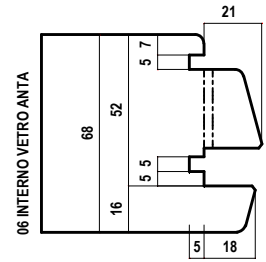
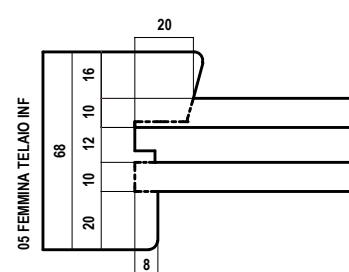
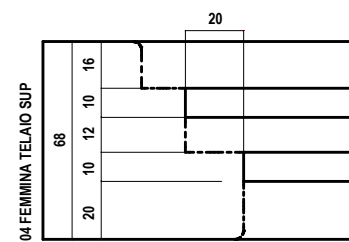
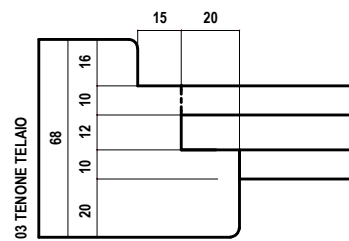
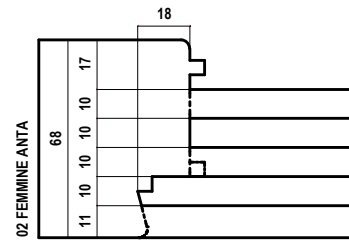
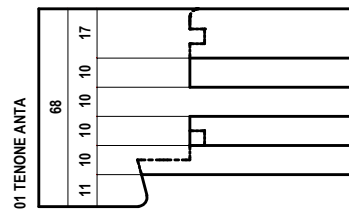
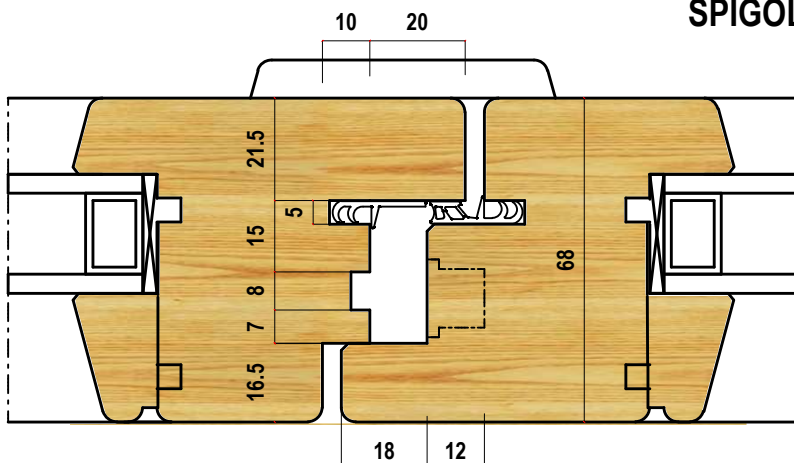
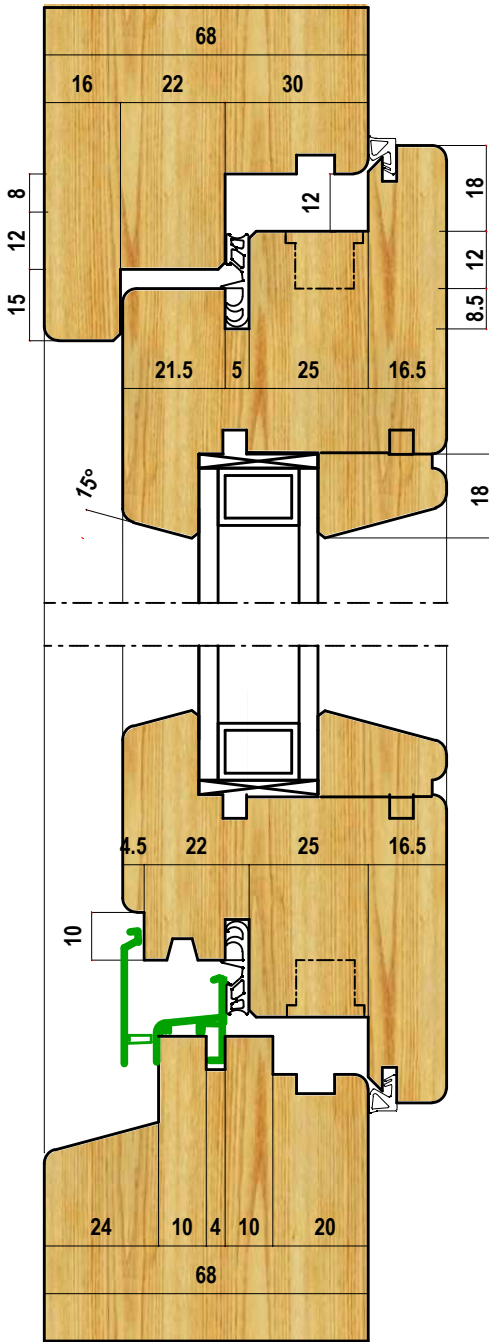

ARIA12
TELAIO e ANTA 68-78 mm
ESTERNO ANTA R3-5
SPIGOLI INTERNI R1-1.5

5/75 ALZANTI SCORREVOLI

SET FOR SLIDING DOORS

ALZANTI SCORREVOLI TIPO GU / AGB

5/75

MAN **MEC**

Codice nr. HW	fresa cutter	D. mm.	B. mm.	d. mm.	Z+V+G3
------------------	-----------------	-----------	-----------	-----------	--------

1	141	15	35	2+2+2
2	185	22	35	2+4
3	141	15	35	2+2+2

4 219 22 35 2+4
OPTIONAL A RICHIESTA / OPTIONAL ON REQUEST

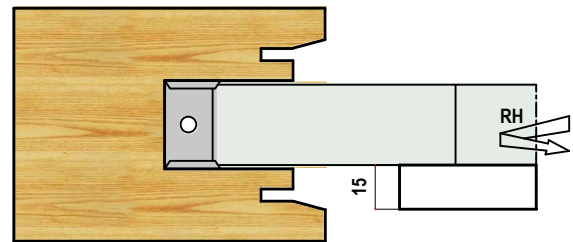
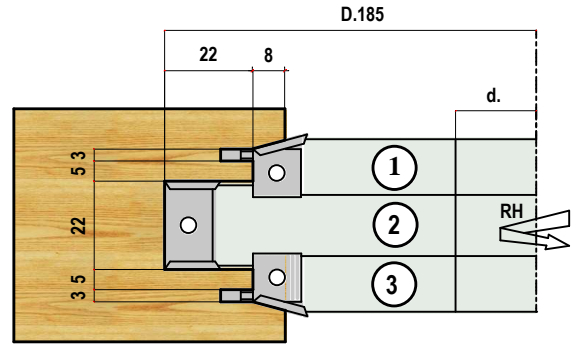

IL GRUPPO VIENE FORNITO DI ANELLO DI COMPENSAZIONE PER RIPASSARE LA FRESA nr.2

5/75 GRUPPO-SET OF TOOLS 1+2+3
FORI A RICHIESTA-BORES AVAILABLE: 30-40-50 mm

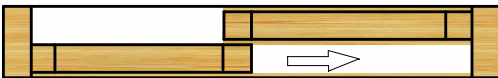
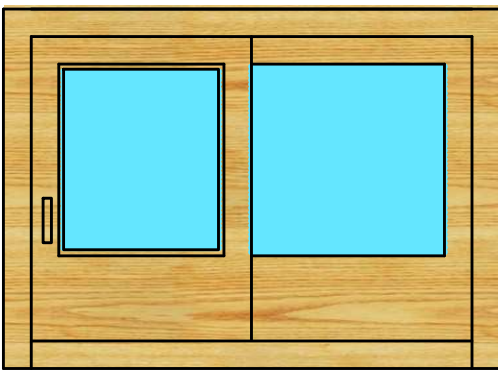

ALZANTI SCORREVOLI TIPO MAICO

AS/M

Codice nr. HW	fresa cutter	D. mm.	B. mm.	d. mm.
------------------	-----------------	-----------	-----------	-----------

AS/M 1 GRUPPO A+B+C+D

AS/M 2 GRUPPO E+F

AS/M 3 207 22 35

AS/M 4 185 22 35

fori a richiesta_bore available:30-40-50

IN ALTERNATIVA AD AS/M3 E AS/M4 USARE
FRESA REGOLABILE D.200 X12.5-22 ART.5R2012

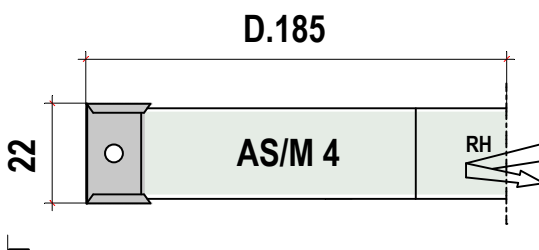
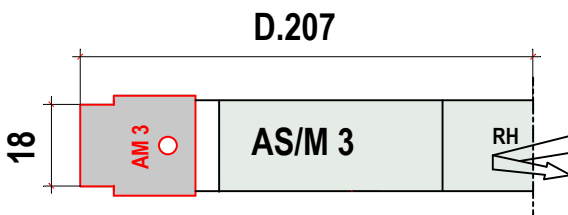
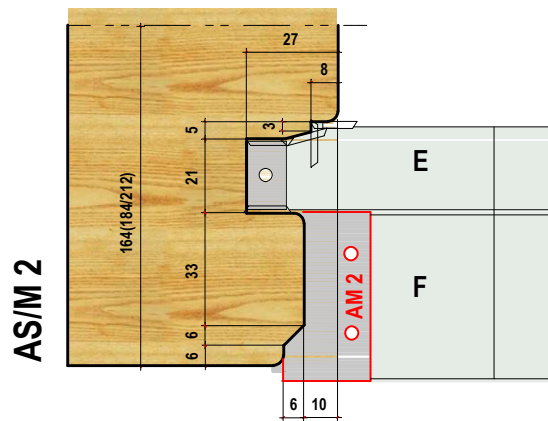
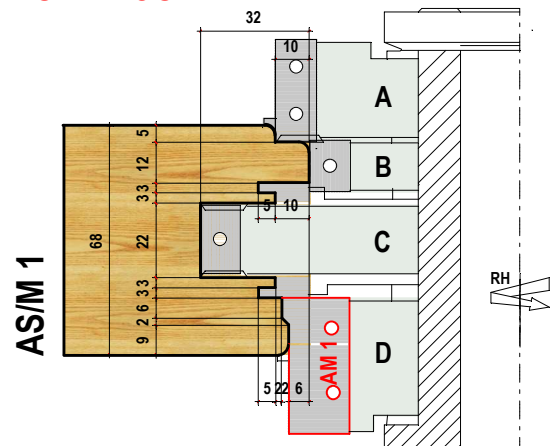

ASR ANTONI A SCURO RAGGIATI

TONGUE AND GROOVE CUTTERS HEADS WITH RADIUSSES

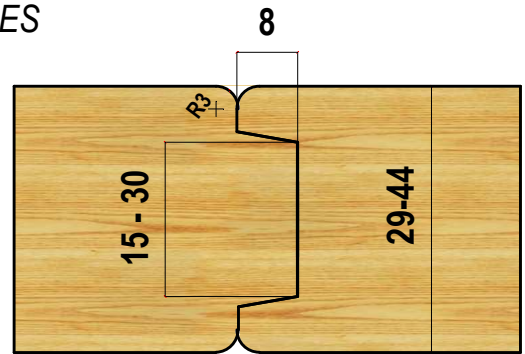

ASR

Codice nr. HW	fresa cutter	D. mm.	B. mm.	d. mm.
------------------	-----------------	-----------	-----------	-----------

ASR 1	GRUPPO A+B			35
ASR 2	GRUPPO C+D			35
ASR 3	FRESA SUPPLEMENTARE			35

fori a richiesta_bore available:30-40-50

FRESE AGGIUNTIVE PER LEGNI FINO 70 mm

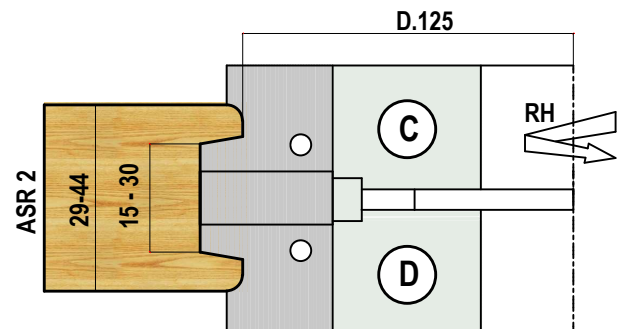
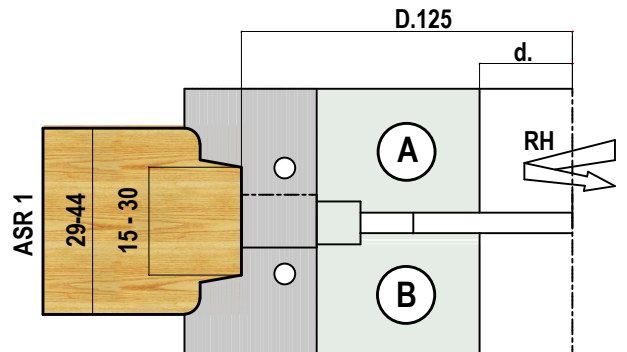
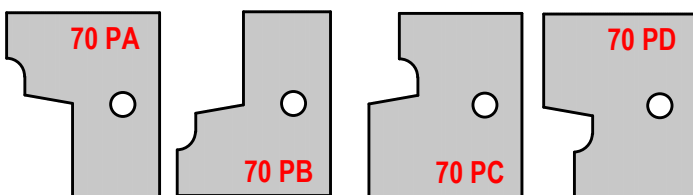

PERSIANE E ANTONI A SCURO

LAVORAZIONE LISTELLI

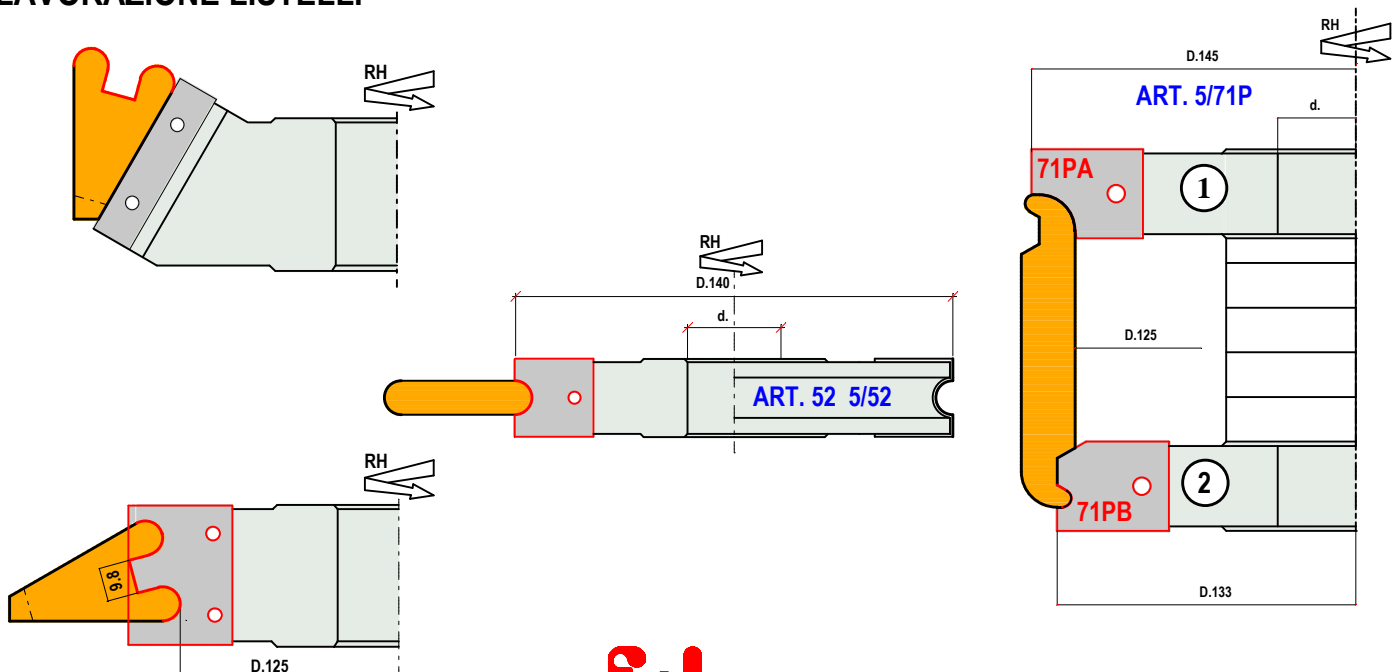

PERSIANE E ANTONI A SCURO

PERSIANA P1

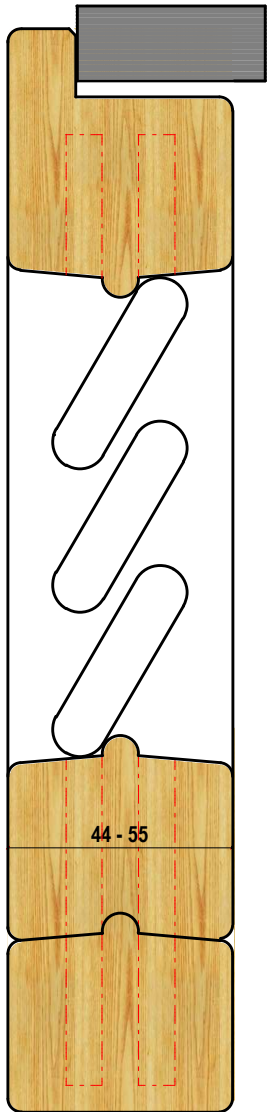

PERSIANA P2

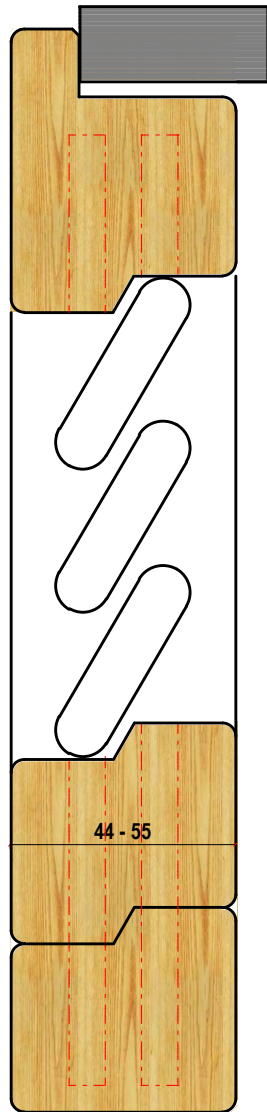

PERSIANA P3

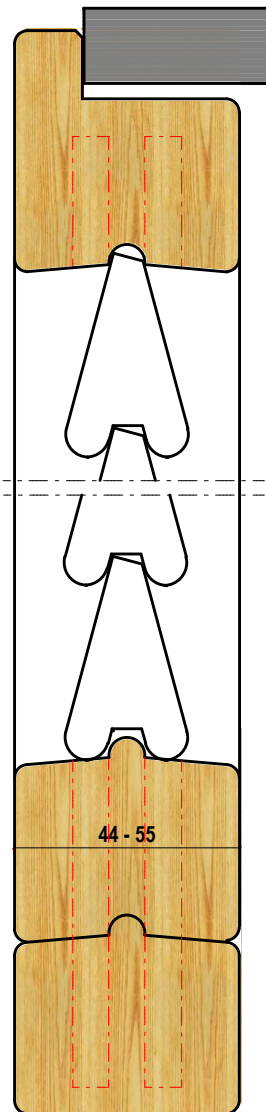

PERSIANA P4

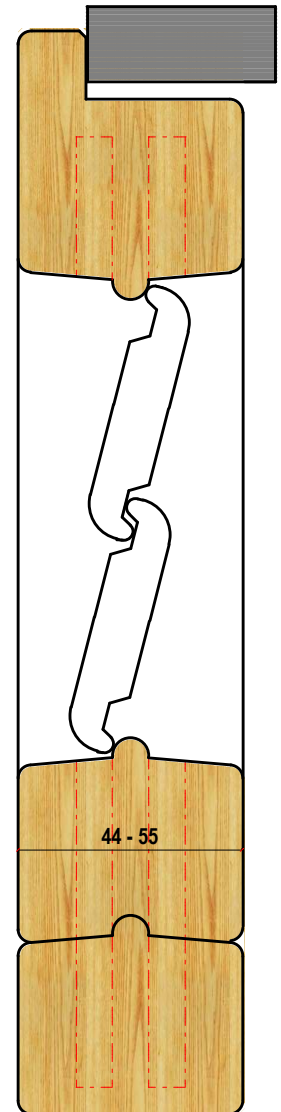

SEZIONE VERTICALE

SEZIONE ORIZZONTALE

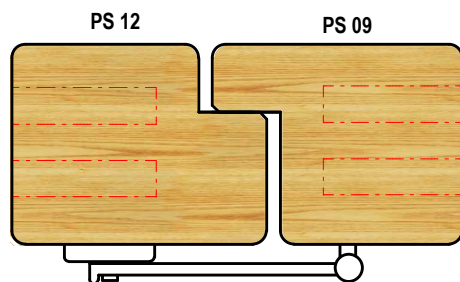
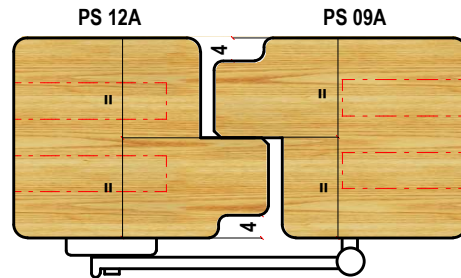
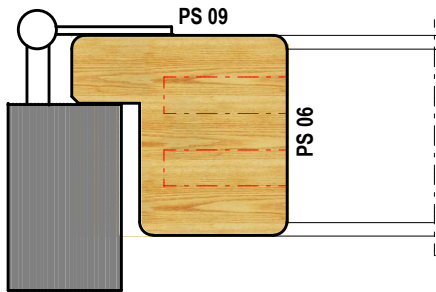

CHIUSURA CENTRALE

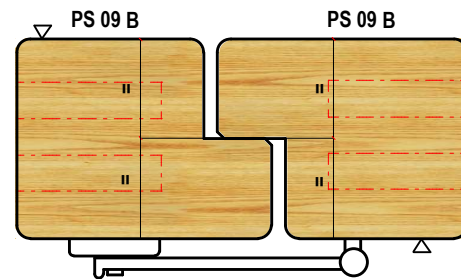

CHIUSURA CENTRALE
SIMMETRICA

PERSIANE E ANTONI A SCURO

TENONATURA

PS 01 TENONE TRAVERSI ANTA

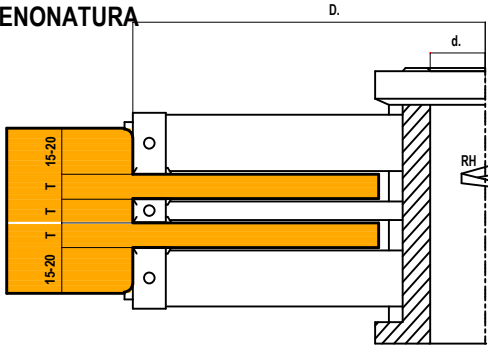

PROFILATURA

PS 07 TRAVERSO INFERIORE

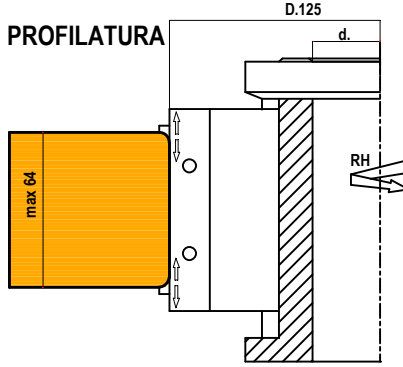

PS 09 SQUADRATURA ANTA

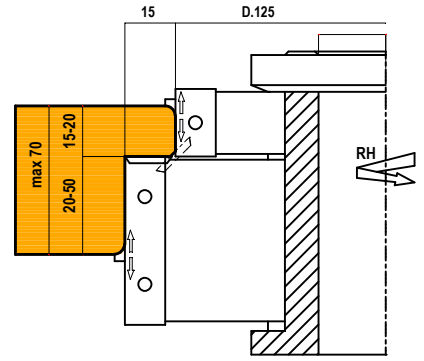

PS 02 TENONE MONTANTI ANTA

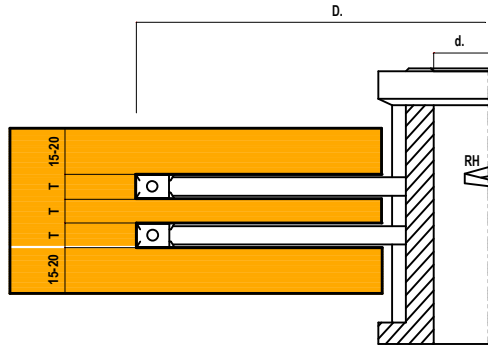

PS 06A INTERNO ANTA

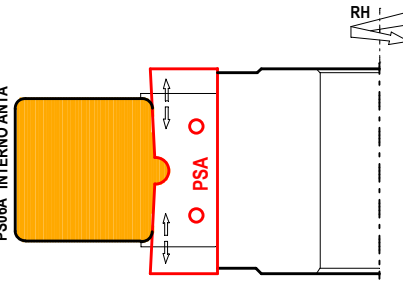

PS 12 CHIUSURA CENTRALE ANTA SINISTRA

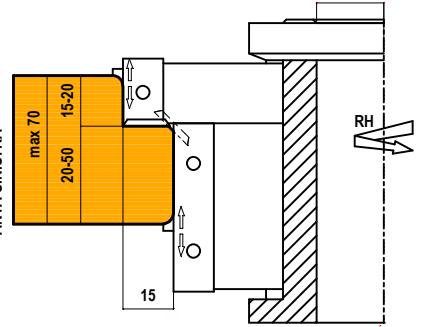

PS 03 TENONE SEMPLICE ANTA

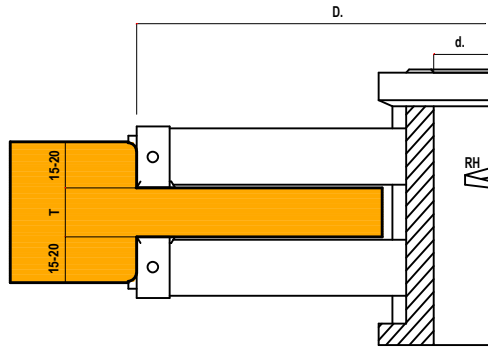

PS 06B TRAVERSO AGGIUNTO

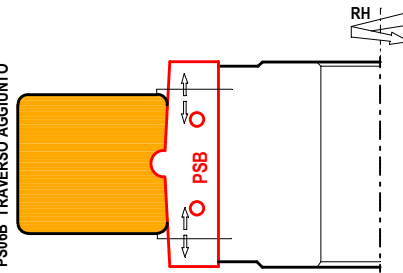

PS 09 B SQUADRATURA ANTA SIMMETRICA

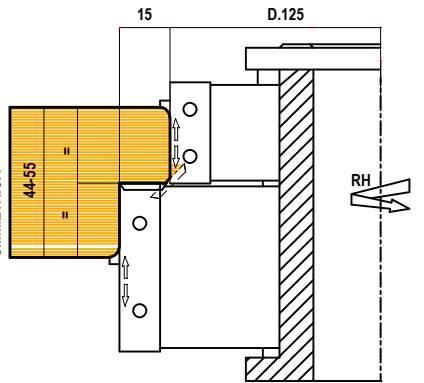

PS 04 TENONE SEMPLICE MONTANTE

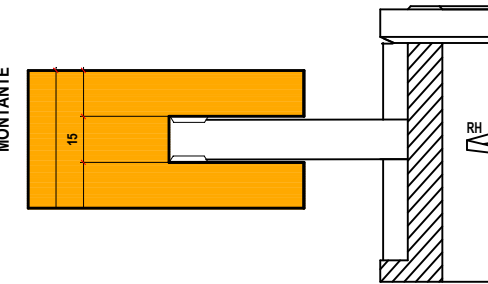

PS 06C INTERNO ANTA

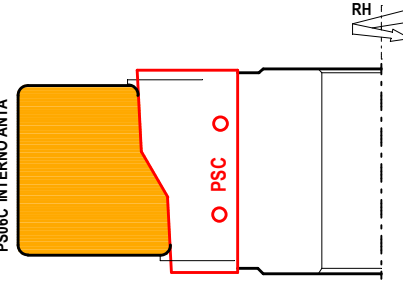

PS 09A SQUADRATURA ANTA

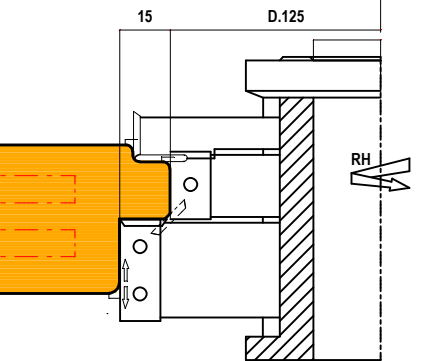

PS 05

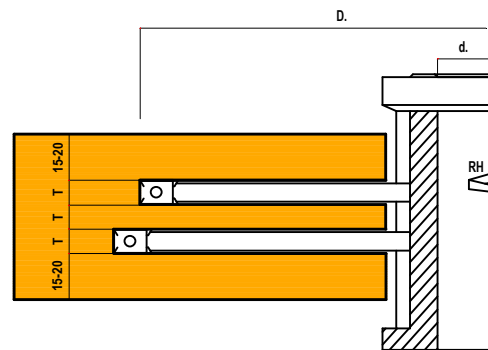

16 TRAVERSO AGGIUNTO

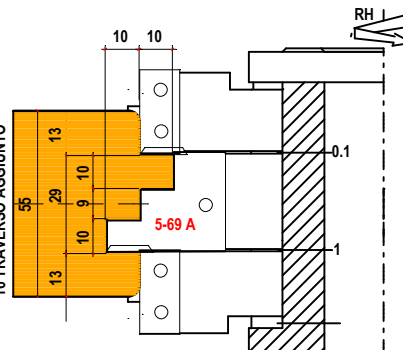

PS 12A CHIUSURA CENTRALE ANTA SINISTRA

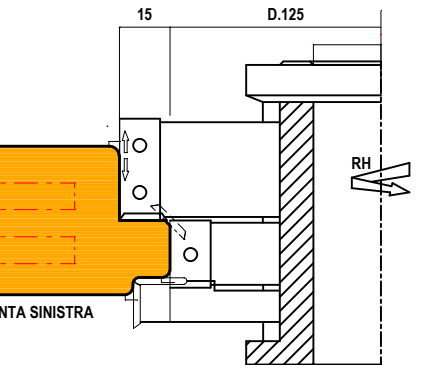

PORTE

TELAIO CLASSICO

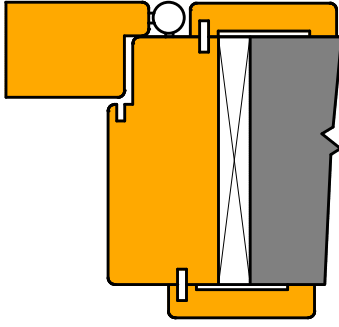

5/67 5/76 5/79 5/79D
 BATTUTE 11mm 15mm
 GIUNZIONI ANGOLARI 5/57 5/68

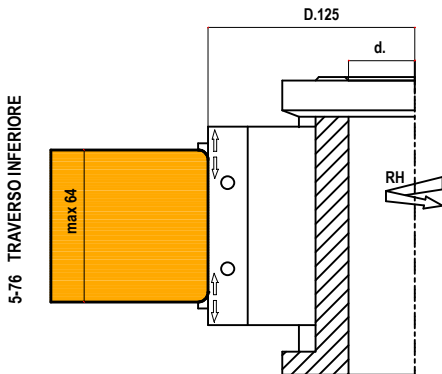
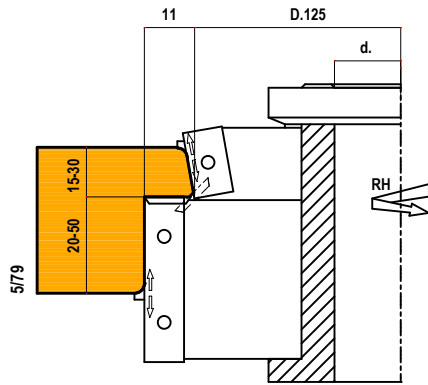
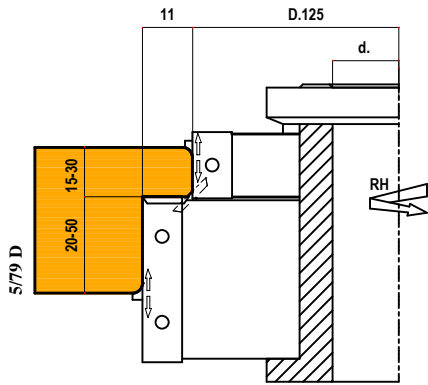

TELAIO TUTTO TONDO

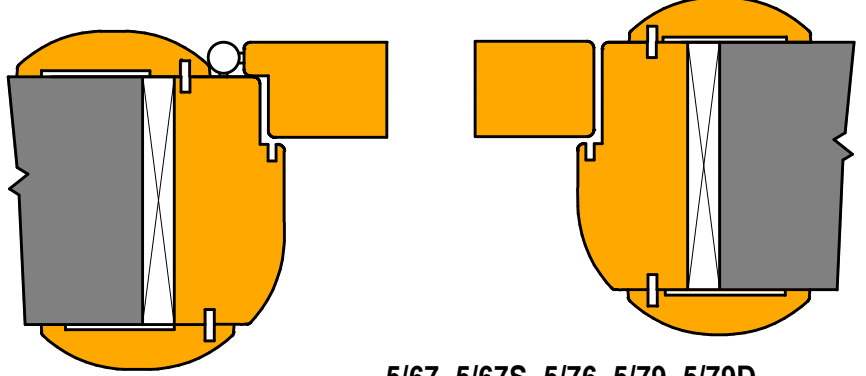

5/67 5/67S 5/76 5/79 5/79D
 GIUNZIONI ANGOLARI 5/57 5/68

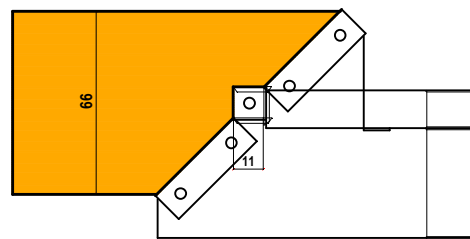
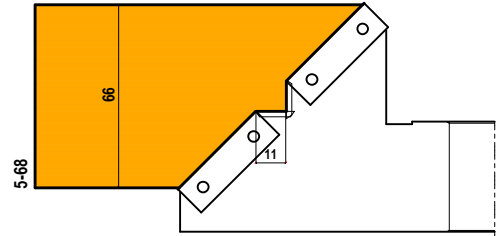
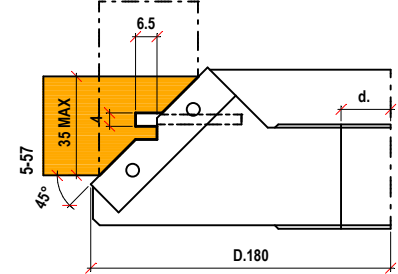
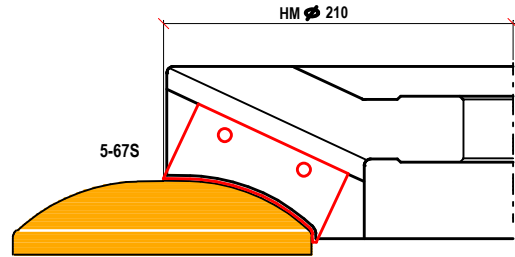
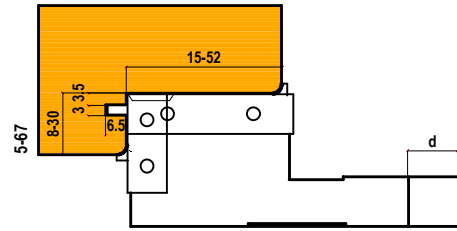

5/136 PORTE E PORTONCINI SAGOMATI

SCALA 1:1
 FULL SIZE SCALE
 PROFILI INTERCAMBIABILI
 PER GRUPPI SERIE 5/136
 INTERCHANGEABLE KNIVES
 ON SERIES 5/136

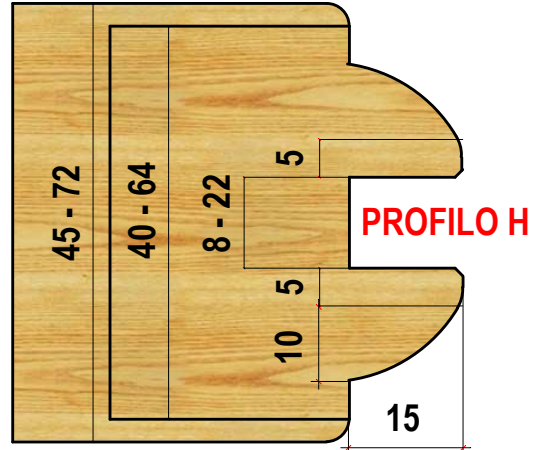
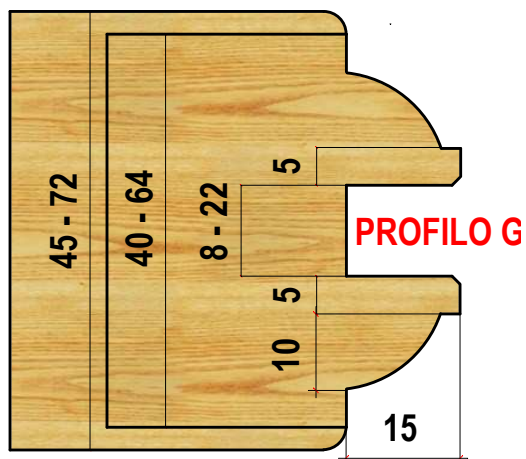
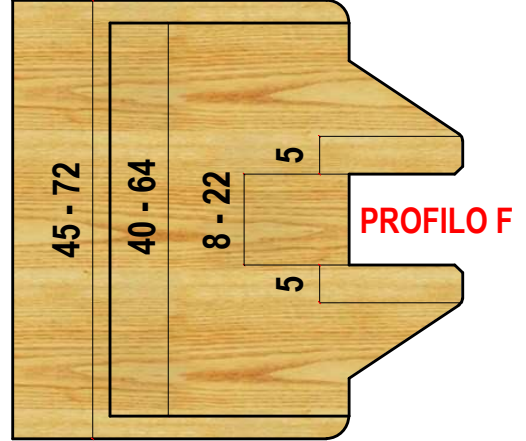
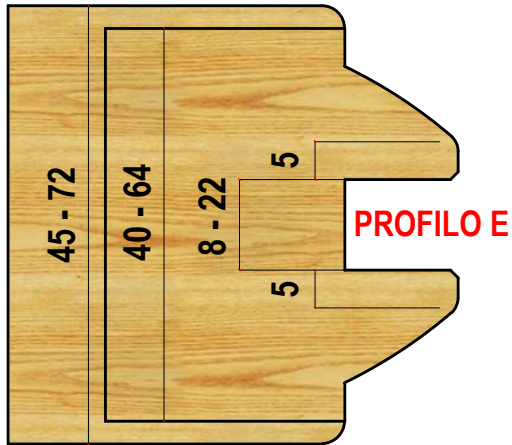
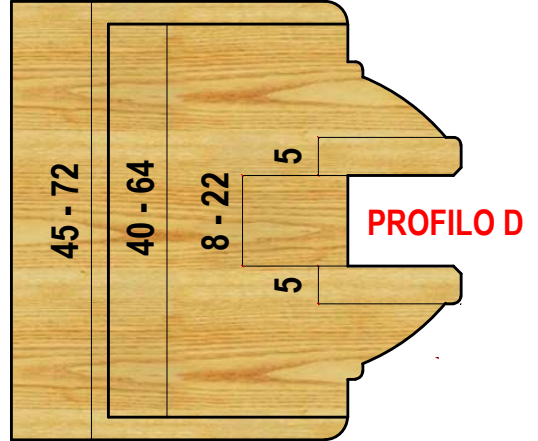
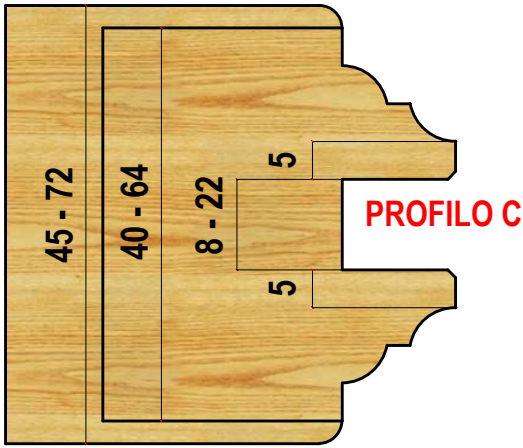
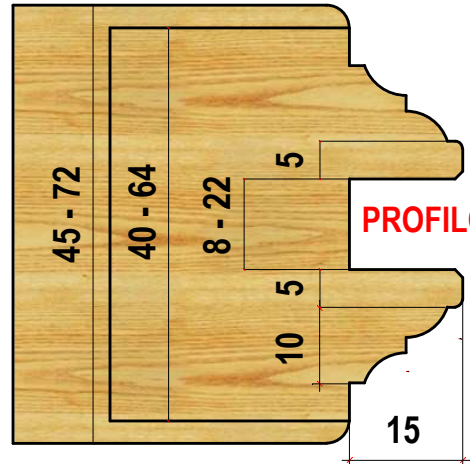
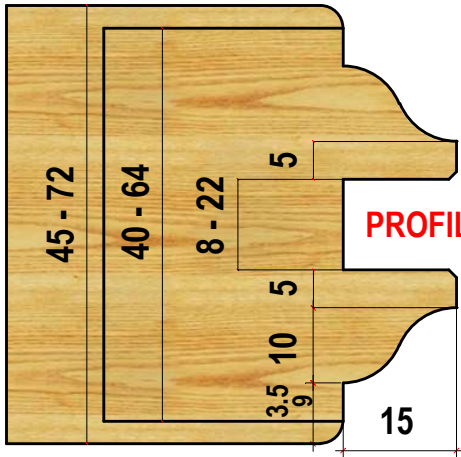

5/36 PORTE SAGOMATE

LEGNO INFILARE

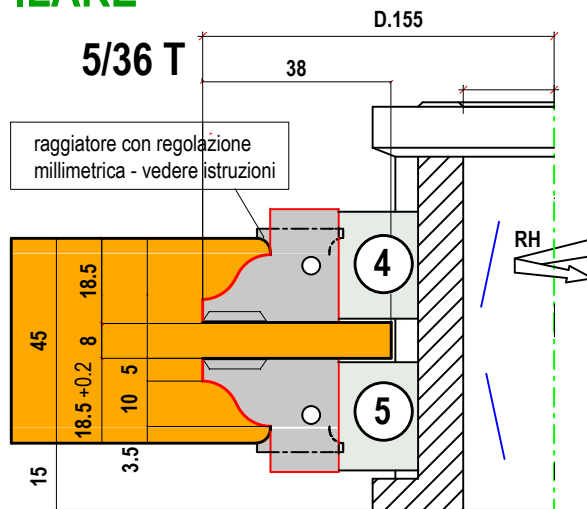
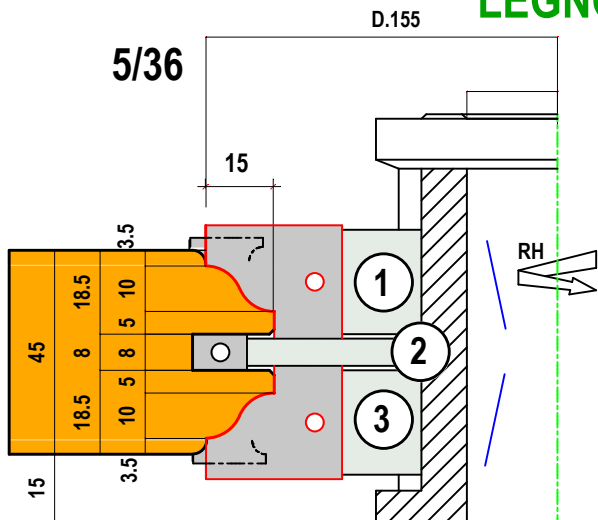

GRUPPI CON RECUPERO LISTELLO

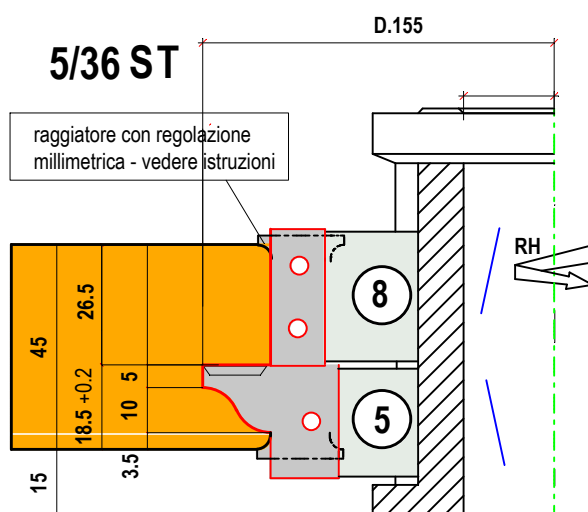
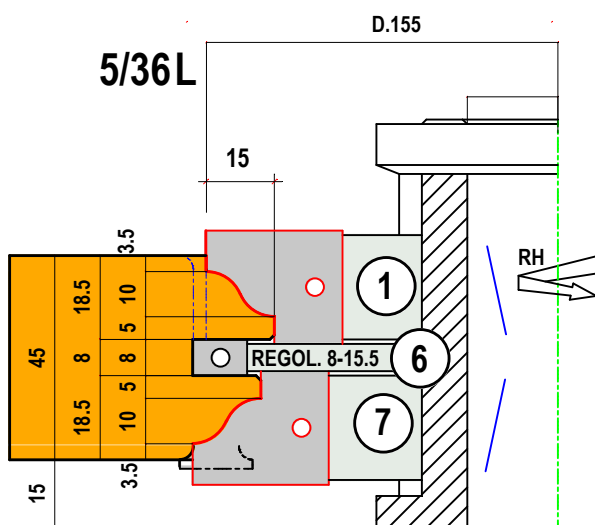
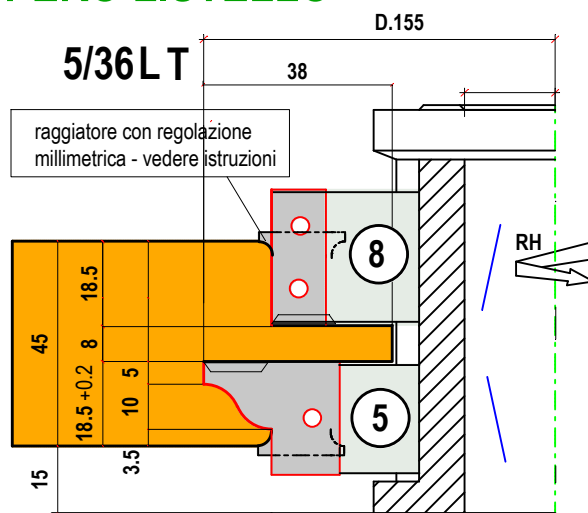
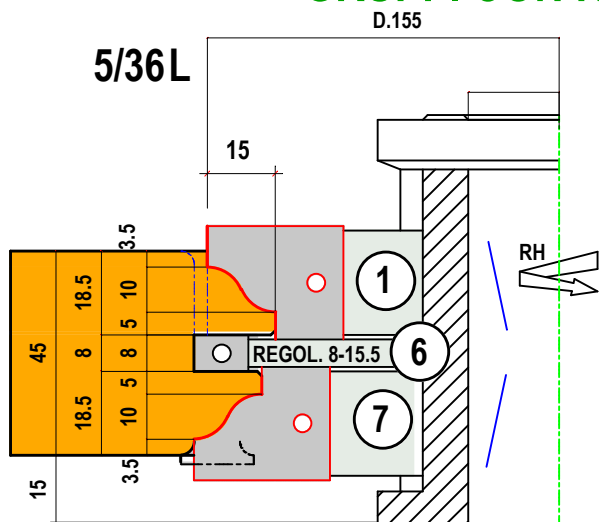

SPESSORI DA 40 mm SENZA RAGGI
FINO A 68 mm CON RAGGI

RECUPERO LISTELLO

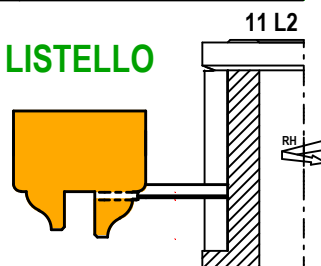

5/36 PORTE SAGOMATE

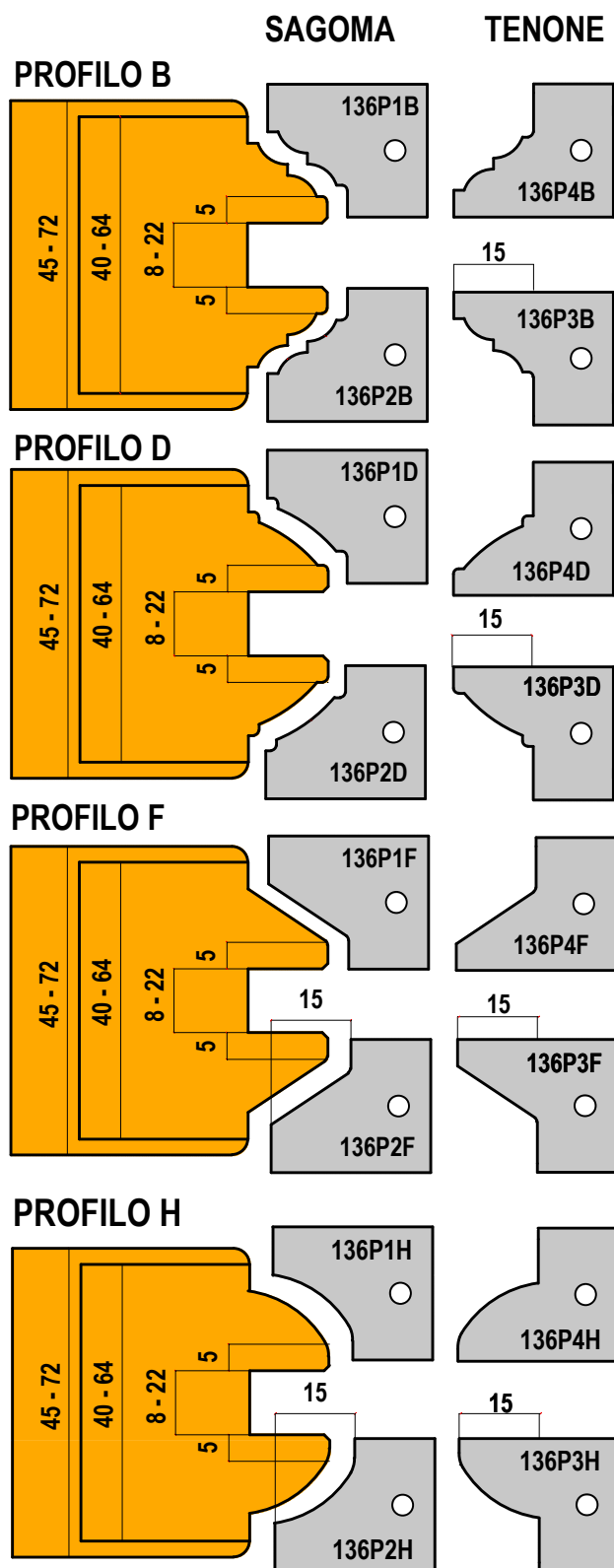
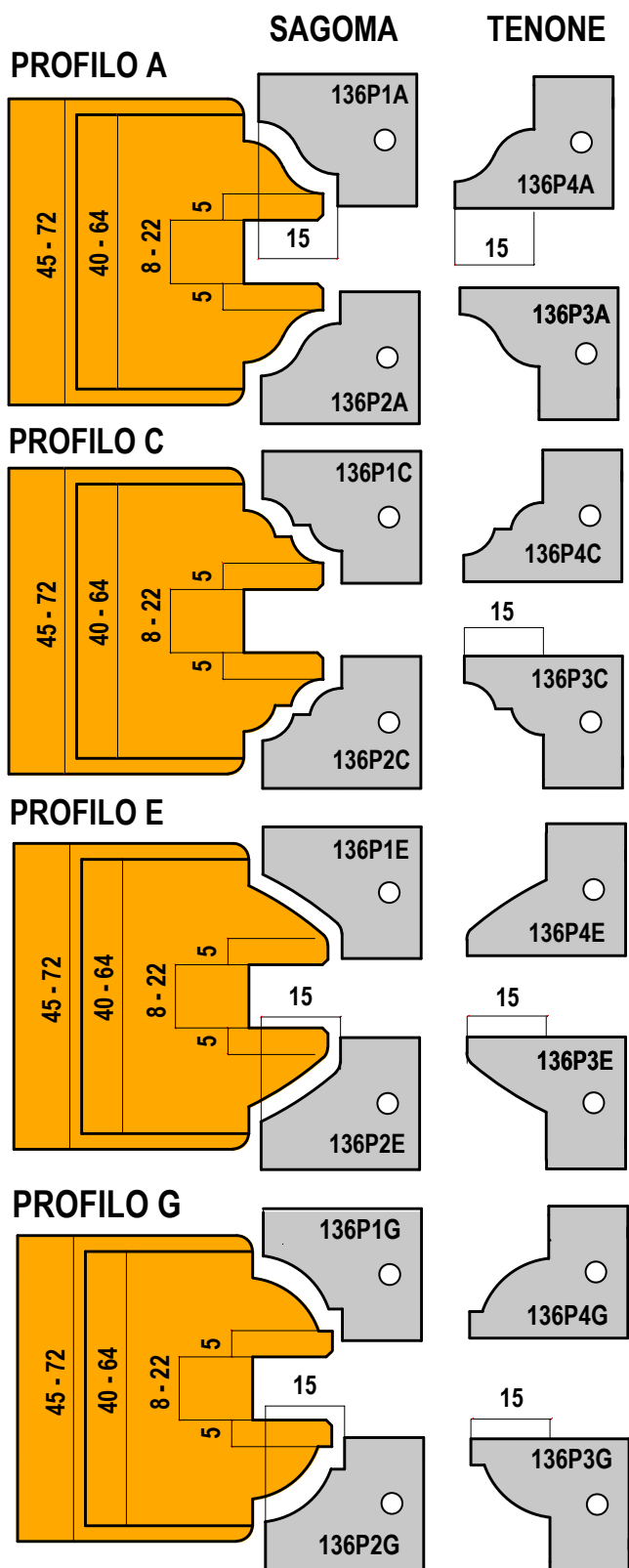

**GRUPPI FORNITI CON UN SOLO PROFILO
A SCELTA TRA GLI 8 DISPONIBILI**

5/136 5P136 GRUPPI PER PORTE

GRUPPI MULTIPROFILO PER PORTE LEGNO INFILARE
 FORNITI CON UN PROFILO A SCELTA TRA GLI 8 DISPONIBILI
 SPESSORI DA 40 mm SENZA RAGGI FINO A 56 mm CON RAGGI
 PROFILI Z=2 TENONI Z=4

MAN

MEC

MULTIPROFILE SET FOR DOORS.
 THE SET IS SUPPLIED WITH ONE
 PROFILE ON CUSTOMER CHOICE.
 PROFILES Z=2 TENONS Z=4

LEGNO INFILARE
 TENONE SEMPLICE

5/136

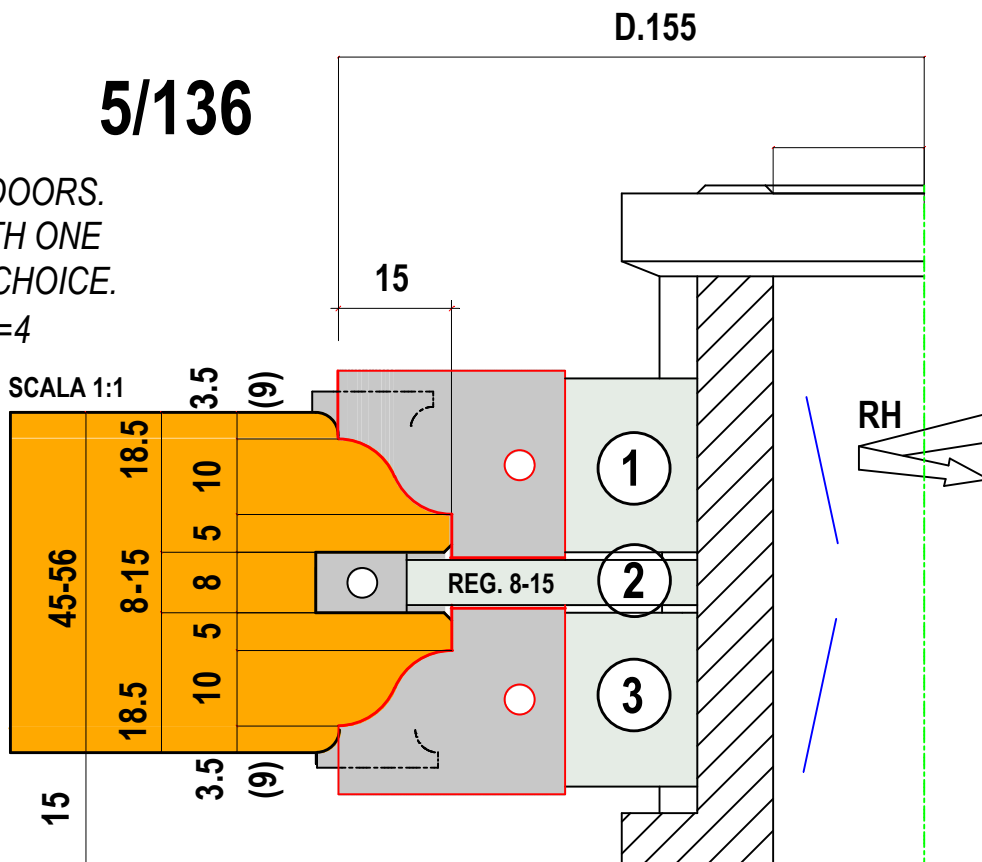

5P136

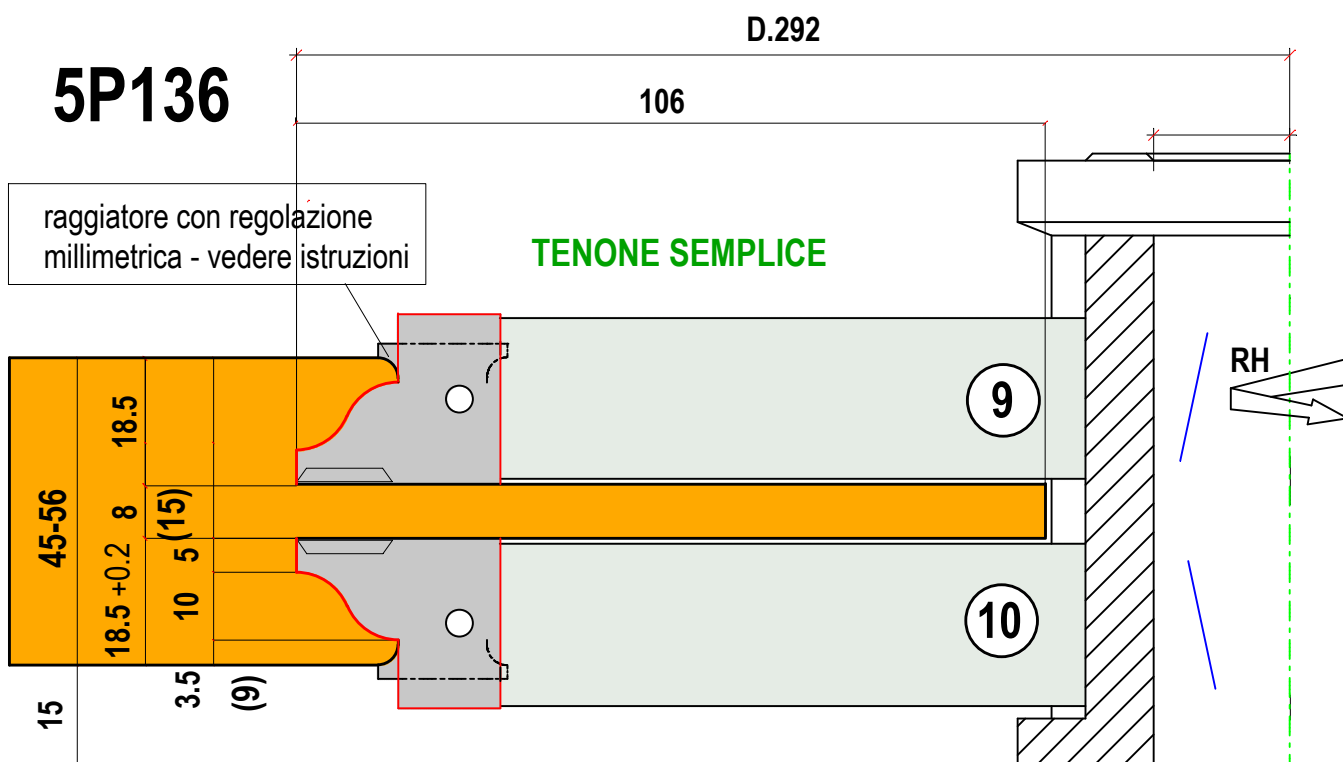

5/136L 5P136L GRUPPI PER PORTONCINI

GRUPPI MULTIPROFILO PER PORTONCINI CON RECUPERO LISTELLO
 FORNITI CON UN PROFILO A SCELTA TRA GLI 8 DISPONIBILI
 PROFILI Z=2 TENONI Z=4

MAN

MEC

**RECUPERO LISTELLO
 TENONE SEMPLICE**

SPESSORI DA 40 mm SENZA RAGGI FINO A 56 mm CON RAGGI
THICKNESS FROM 40 mm WITHOUT RADIUSSES TO 56mm WITH RADIUSSE

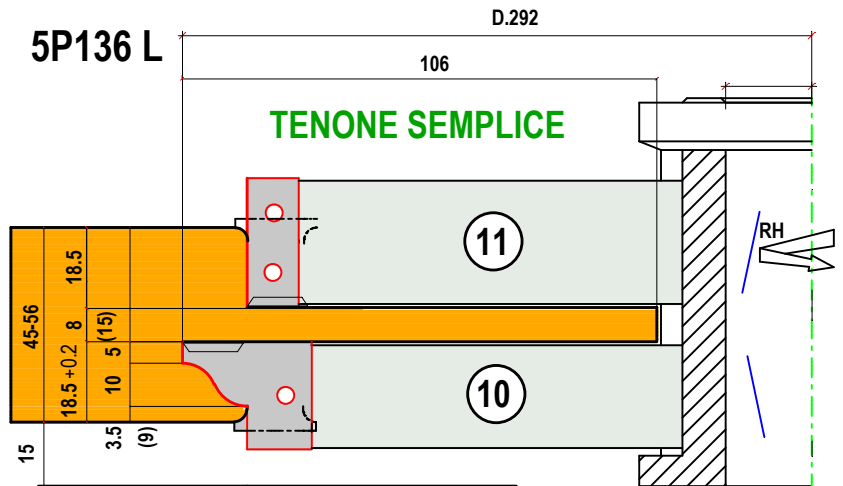
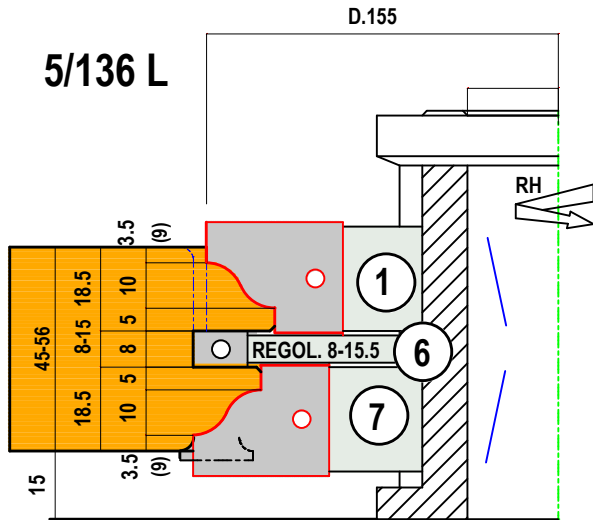

MULTIPROFILE SET FOR DOORS.
 THE SET IS SUPPLIED WITH ONE
 PROFILE ON CUSTOMER CHOICE.
 PROFILES Z=2 TENONS Z=4

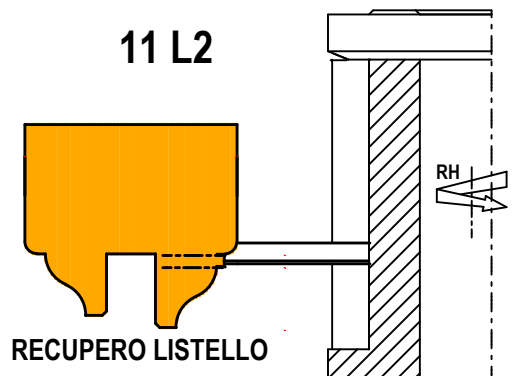

5/136L2 5P136L2

**RECUPERO LISTELLO
 TENONE DOPPIO**

SPESSORI DA 48 mm FINO A 72 mm
THICKNESS FROM 48 mm TO 72 mm

MEC

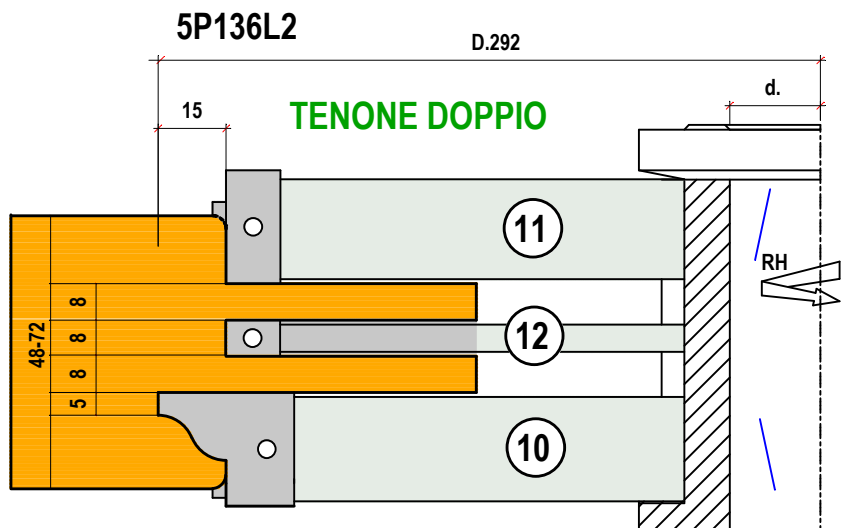
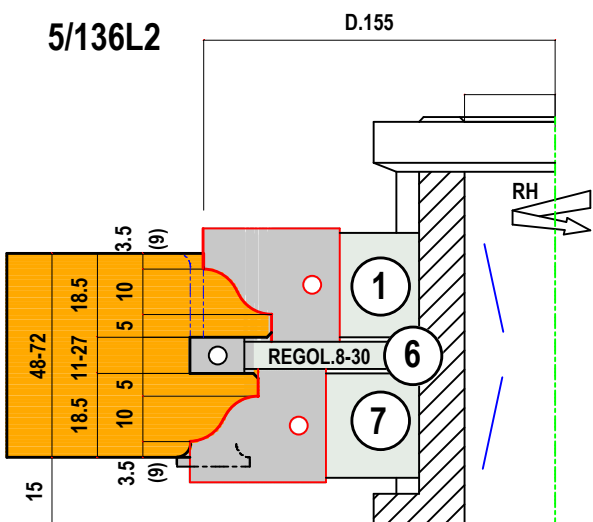

5/137 5P137 LEGNO INFILARE

GRUPPI PER PORTE PER VETRO O PANNELLO AD INFILARE.
SET FOR DOORS WITH SINGLE INSERTED GLASS OR WOOD PANEL.

PROFILI Z=2 TENONI Z=4
PROFILES Z=2 TENONS Z=4

MAN **MEC**

TENONE SEMPLICE SPESSORE 36-42 mm THICKNESS 36-42 mm

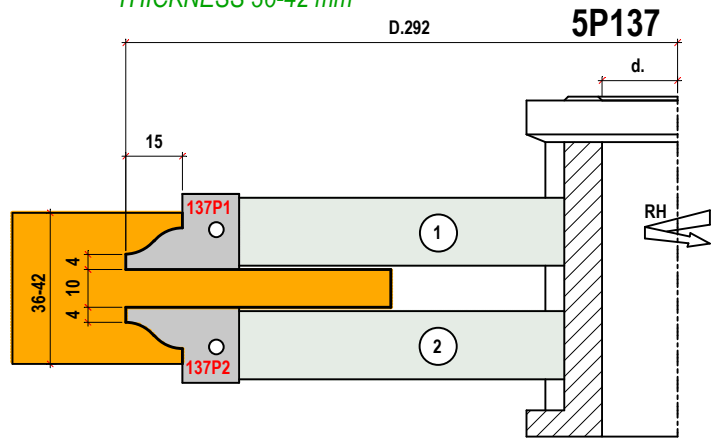
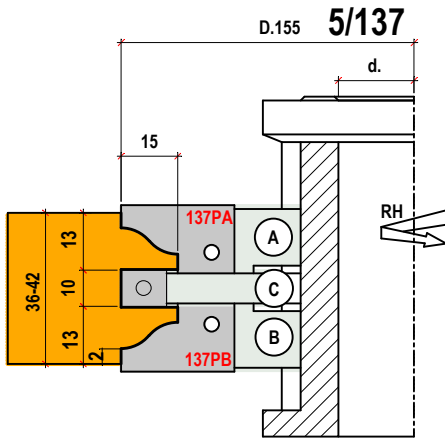

TENONE SEMPLICE CON RAGGI SPESSORE 39-45 mm THICKNESS 39-45 mm

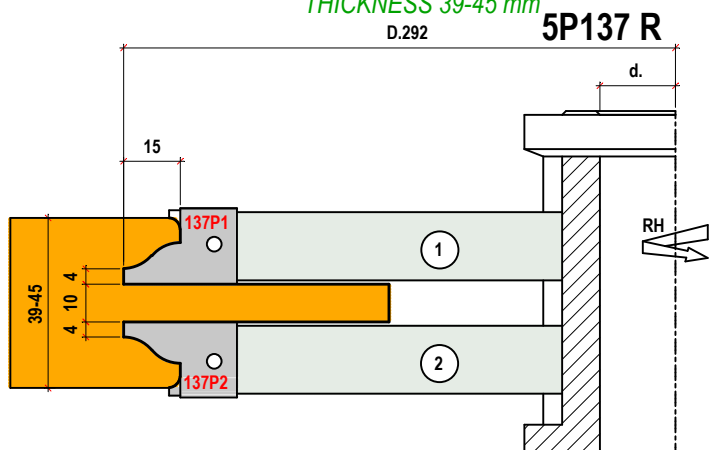
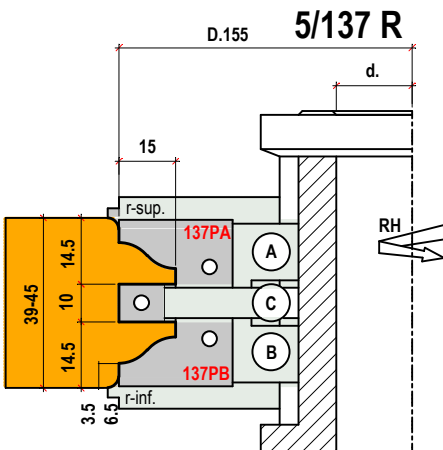

TENONE SEMPLICE CON RAGGI SPESSORE 44-50 mm THICKNESS 44-50 mm

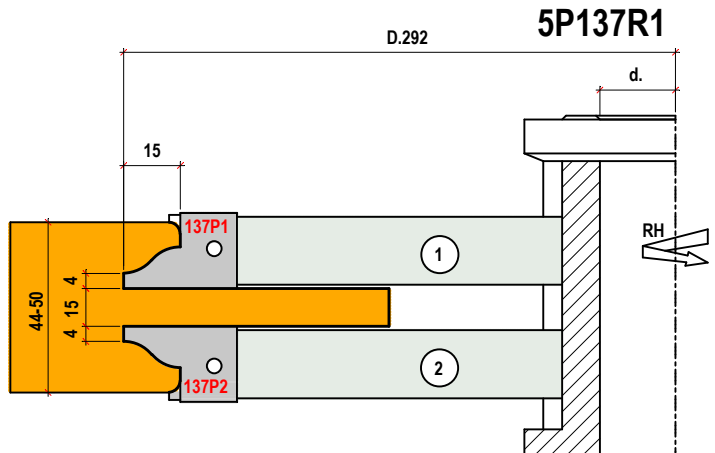
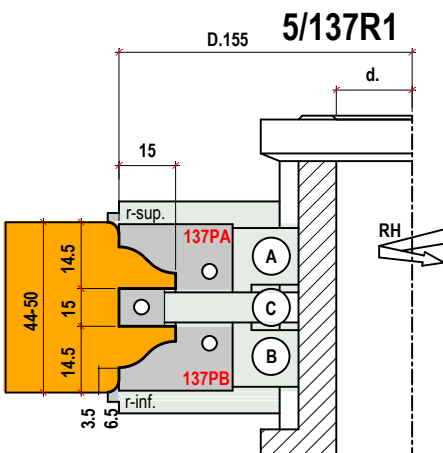

5/137L 5P137L GRUPPI PER PORTONCINI

MAN

MEC

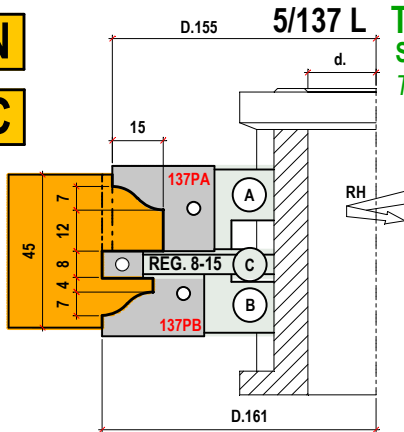

5/137 L TENONE SEMPLICE
SPESSORE 45-54 mm
THICKNESS 45-54 mm

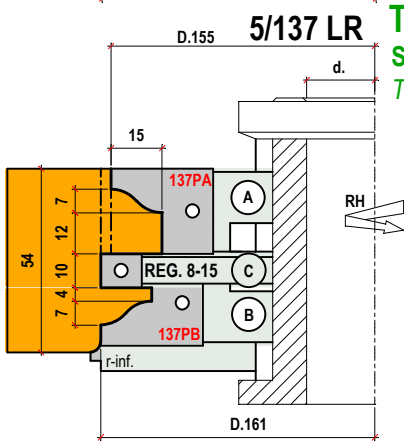
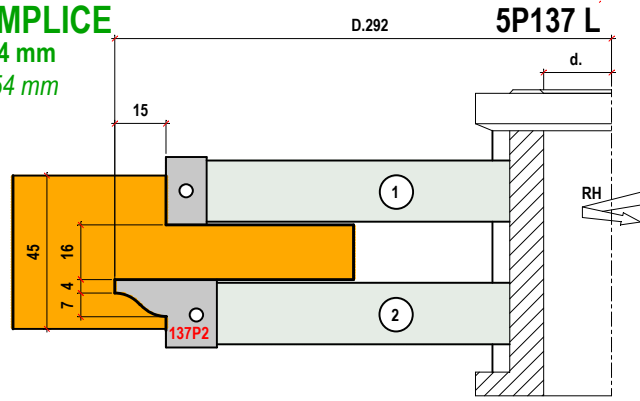

5/137 LR TENONE SEMPLICE CON RAGGI
SPESSORE 54-59 mm
THICKNESS 54-59mm

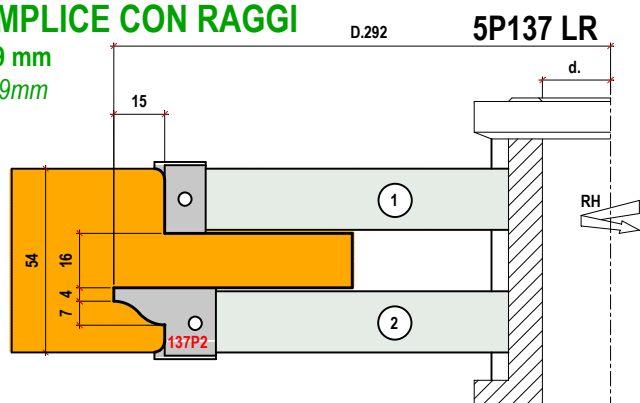

GRUPPI PER PORTE PER VETRO O PANNELLO AD INFILARE.
SET FOR DOORS WITH SINGLE INSERTED GLASS OR WOOD PANEL.

RECUPERO LISTELLO

PROFILI Z=2 TENONI Z=4
PROFILES Z=2 TENONS Z=4

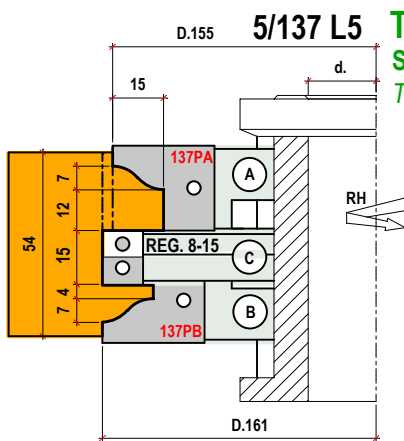
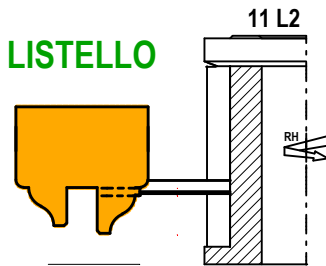

5/137 L5 TENONE DOPPIO
SPESSORE 54-56 mm
THICKNESS 54-56 mm

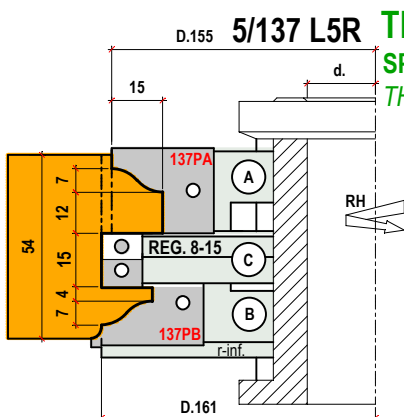
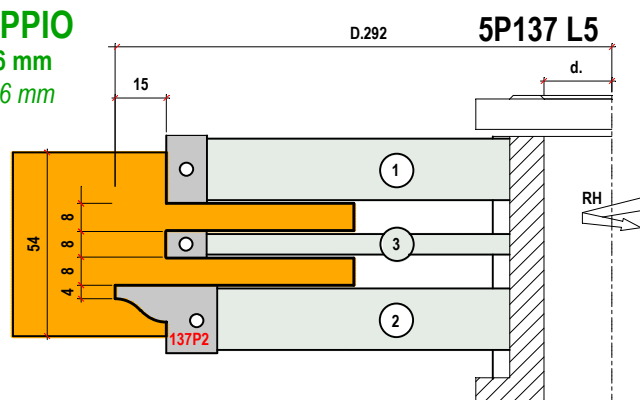

5/137 L5R TENONE DOPPIO CON RAGGI
SPESSORE 54-59 mm
THICKNESS 54-59 mm

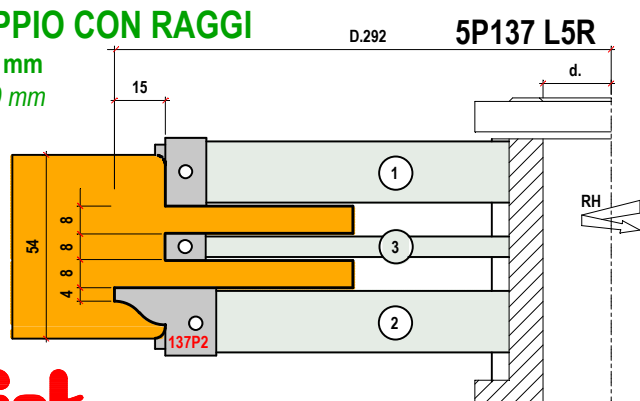

5/137 PROFILI E RICAMBI

PROFILI INTERCAMBIABILI PER GRUPPI 5/137 DAL 2011

SPESSORI DA 40 A 59 mm SECONDO LE VERSIONI.

PROFILES INTERCHANGEABLE ON SET 5/137 FROM YEAR 2011

THICKNESS FROM 40 TO 59 mm ACCORDING THE VERSION TYPE.

SCALA 1:1

FULL SIZE SCALE

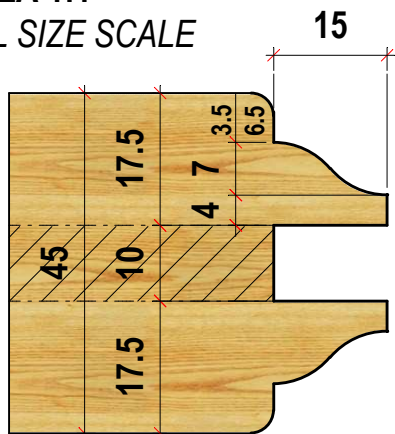

SAGOMA

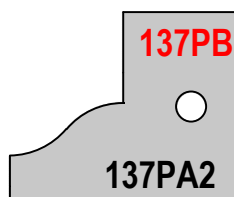
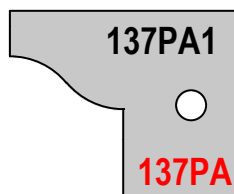

TENONE

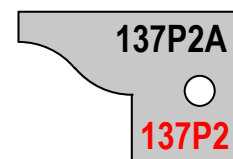
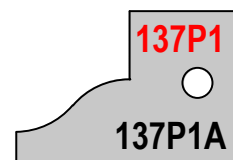

CODICI IN COLORE ROSSO VALGONO PER UTENSILI VENDUTI FINO AL 31-12-2010

CODICI IN COLORE NERO VALGONO PER UTENSILI VENDUTI A PARTIRE DAL 2011

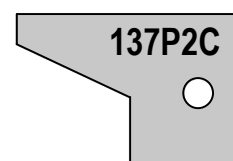
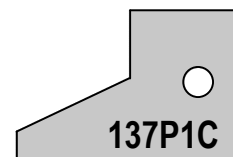
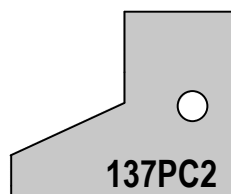
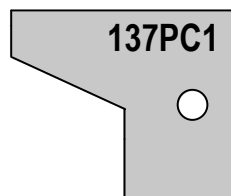
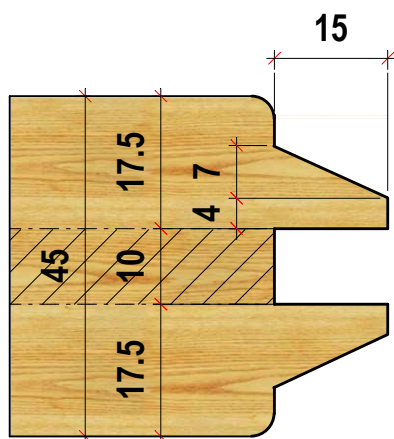
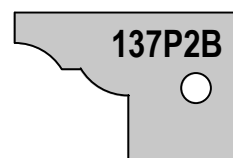
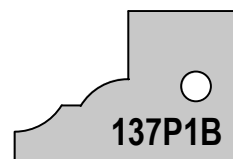
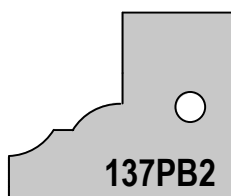
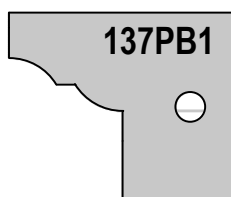
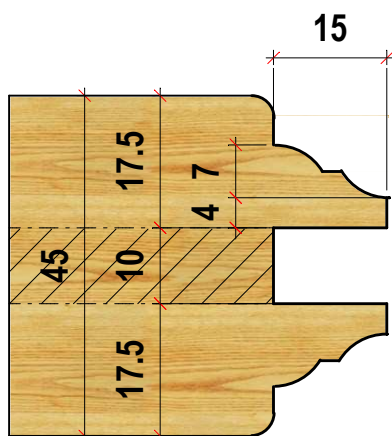

COLTELLINI DI RICAMBIO

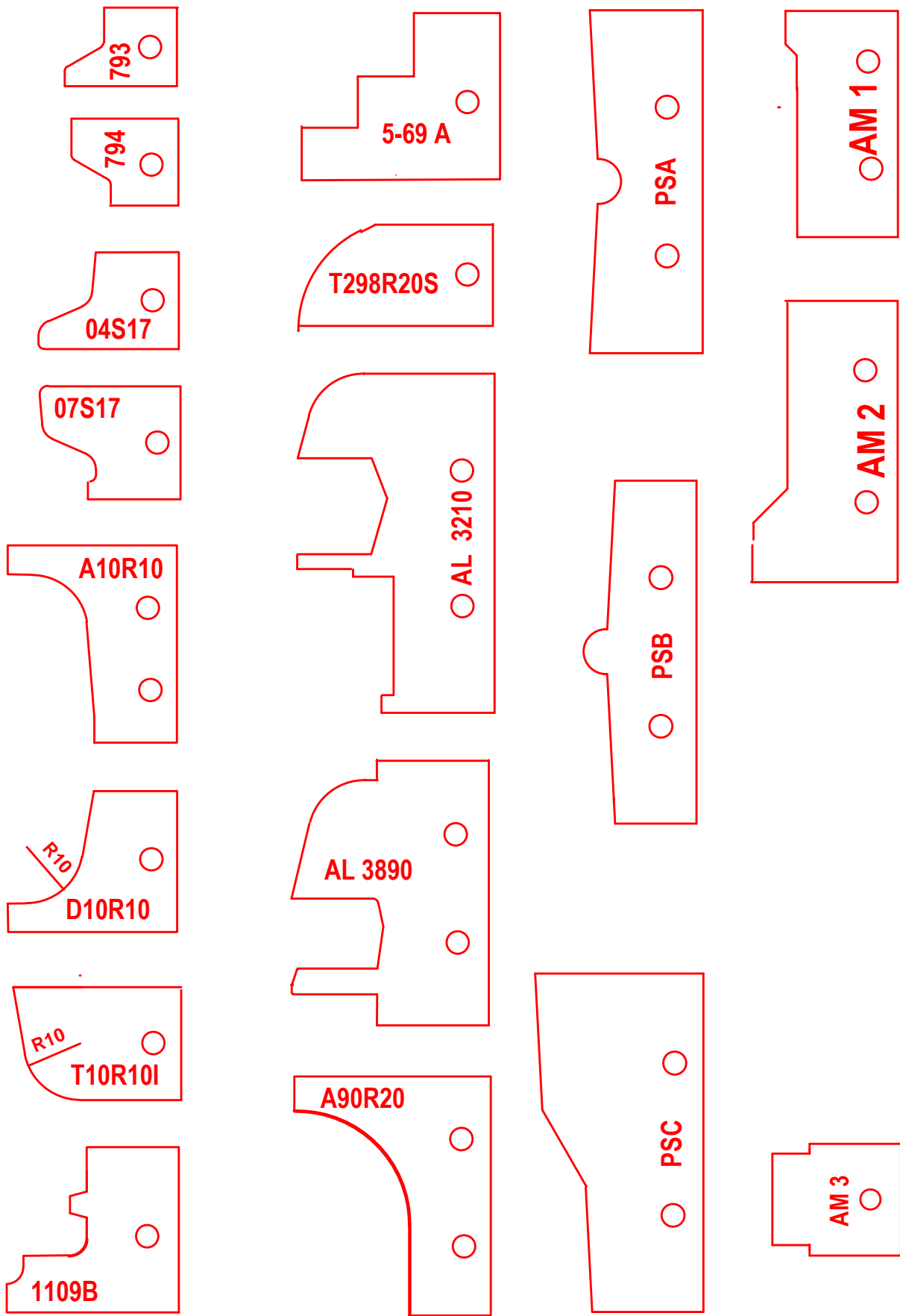



fink

FINK s.r.l.
Via G.Giusti 15
20900 Monza - MB
tel: +39 - 039 - 386961
tel: +39 - 039 - 386962
fax: +39 - 039 - 361458
e-mail: fink@finktools.com
www.finktools.com

