

# COLTELLI PROFILATI DA 40 x 4 mm

COLTELLI E LIMITATORI IN ACCIAIO SP  
DA 40 x 4 mm. DA USARE SULLE TESTE  
TIPO 102-103.

PROFILED KNIVES AND DEFLECTORS  
IN SP STEEL 40 x 4 mm. TO USE WITH  
HEADS TYPE 102-103.

**CODICE COLTELLO 119N....**

**KNIFE CODE 119N....**

**CODICE LIMITATORE 119C....**

**DEFLECTOR CODE 119C....**

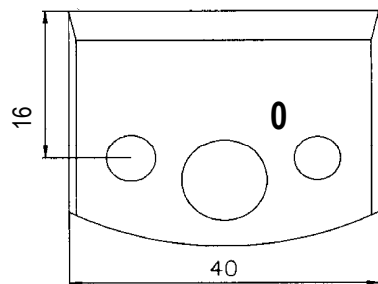

**102-16 / 102-C**

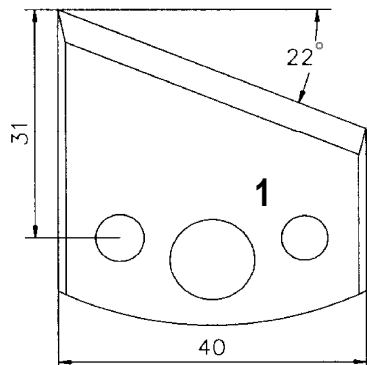

**119N01 / 119C01**

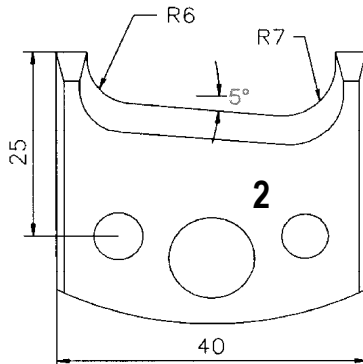

**119N02 / 119C02**

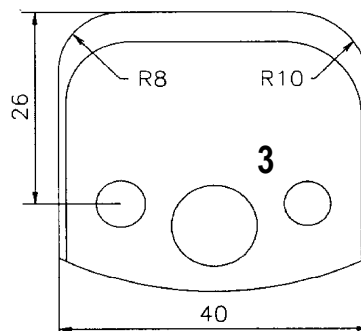

**119N03 / 119C03**

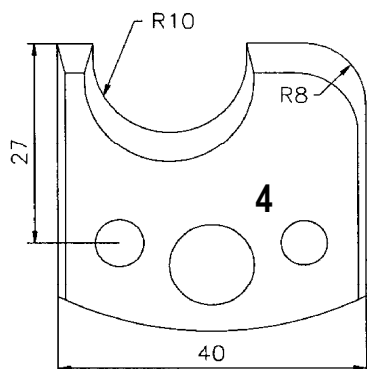

**119N04 / 119C04**

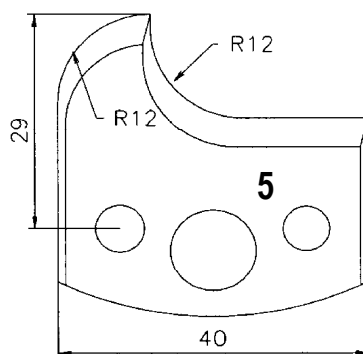

**119N05 / 119C05**

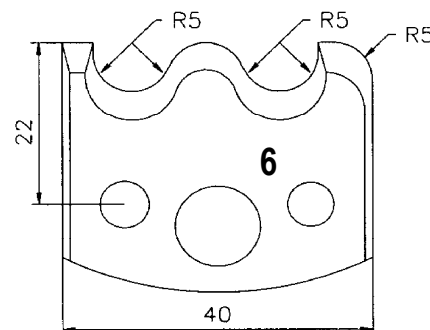

**119N06 / 119C06**

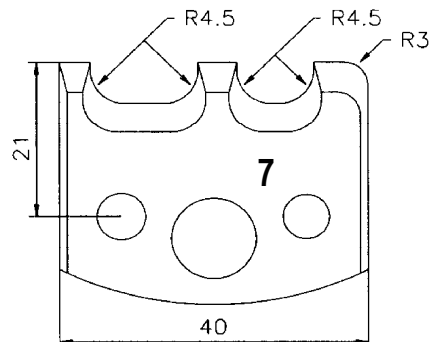

**119N07 / 119C07**

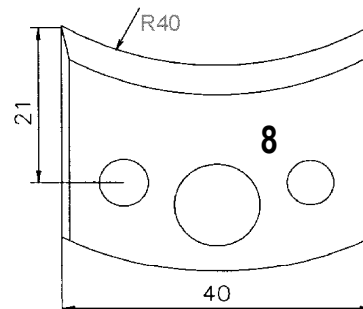

**119N08 / 119C08**

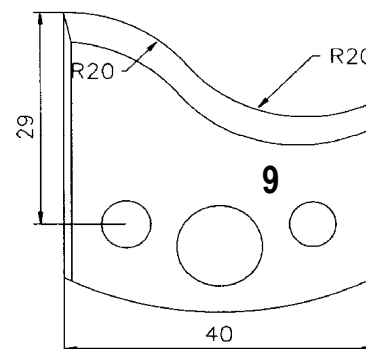

**119N09 / 119C09**

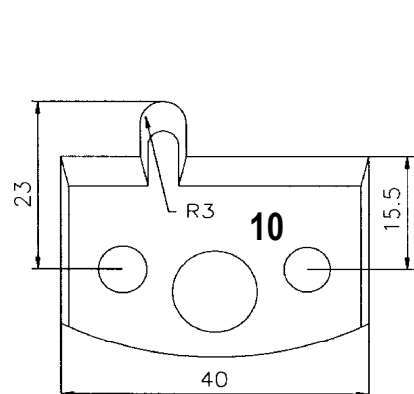

**119N10 / 119C10**

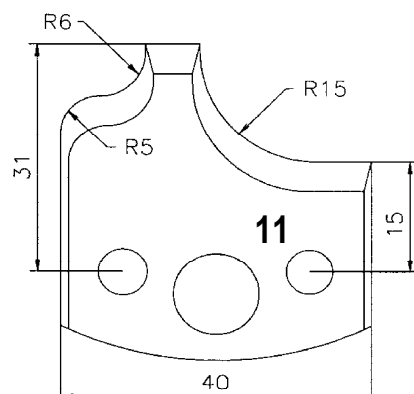

**119N11 / 119C11**

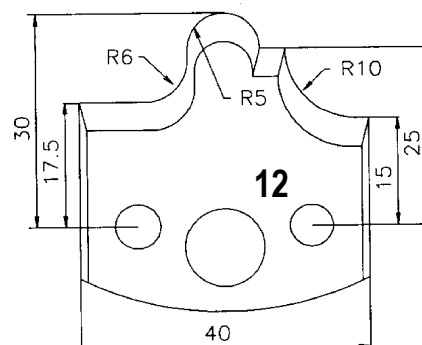

**119N12 / 119C12**

# COLTELLI PROFILATI DA 40 x 4 mm

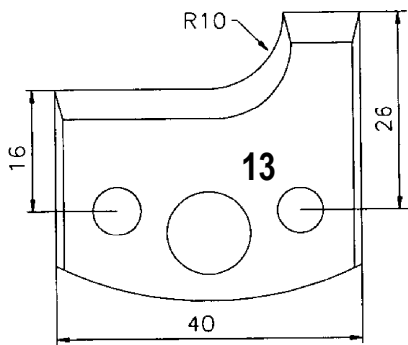

119N13 / 119C13

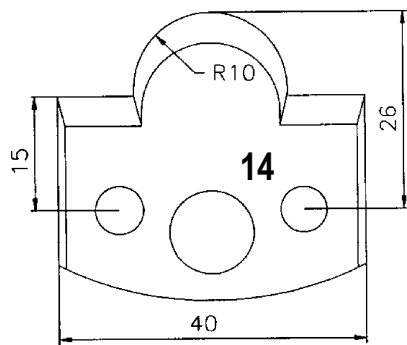

119N14 / 119C14

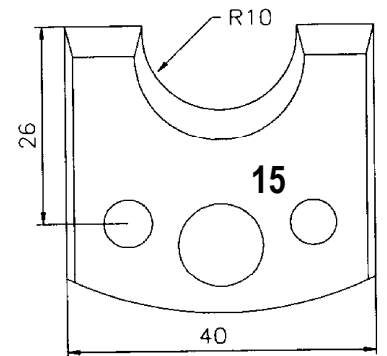

119N15 / 119C15

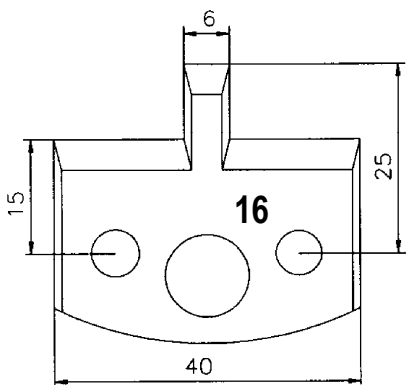

119N16 / 119C16

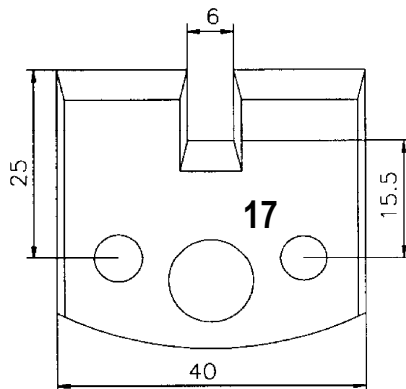

119N17 / 119C17

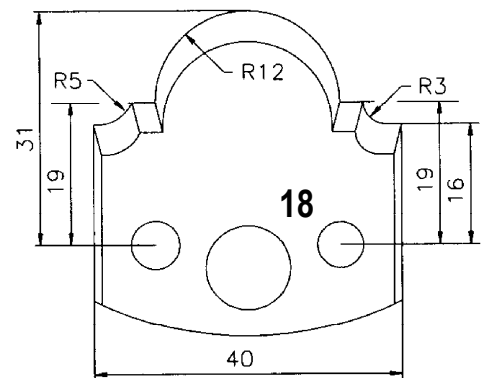

119N18 / 119C18

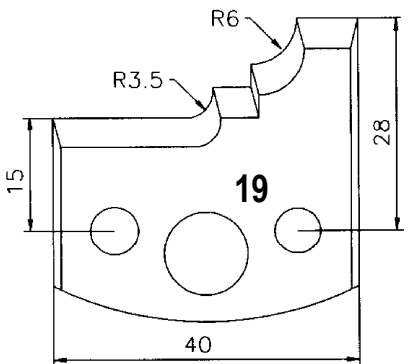

119N19 / 119C19

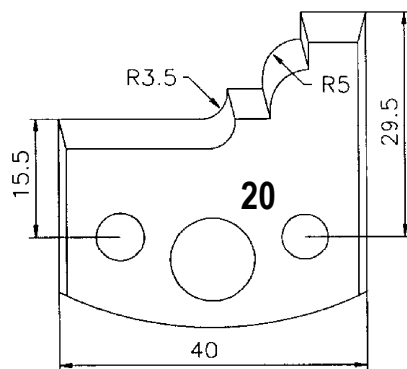

119N20 / 119C20

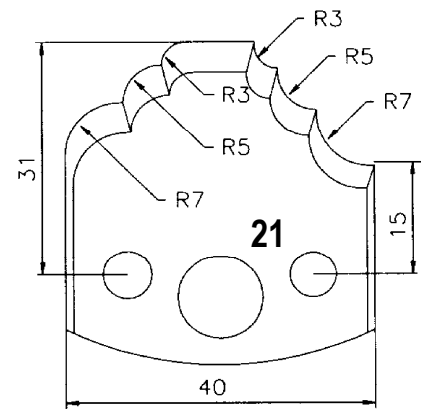

119N21 / 119C21

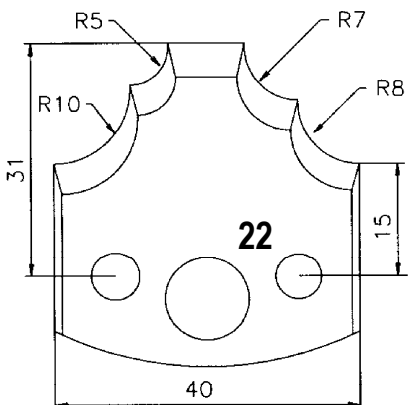

119N22 / 119C22

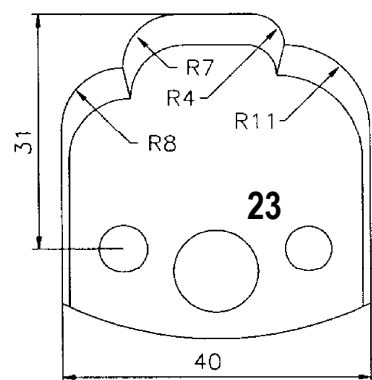

119N23 / 119C23

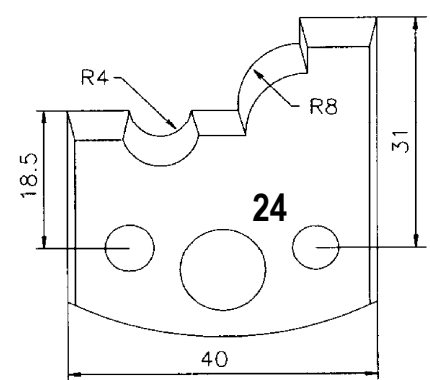

119N24 / 119C24

# COLTELLI PROFILATI DA 40 x 4 mm

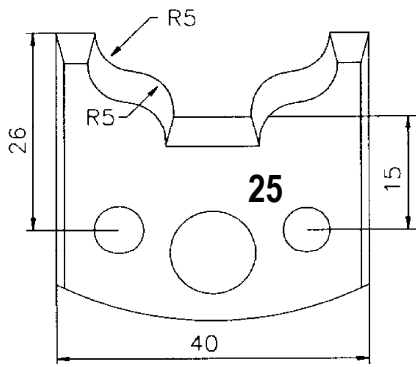

119N25 / 119C25

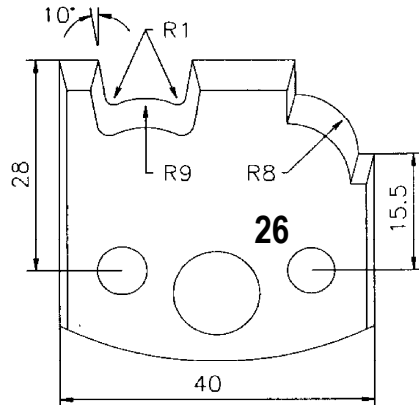

119N26 / 119C26

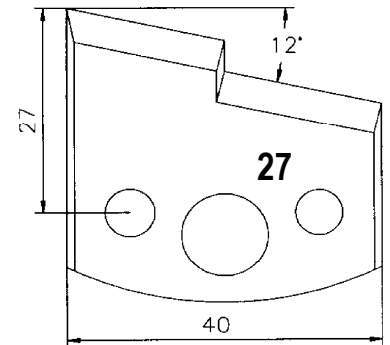

119N27 / 119C27

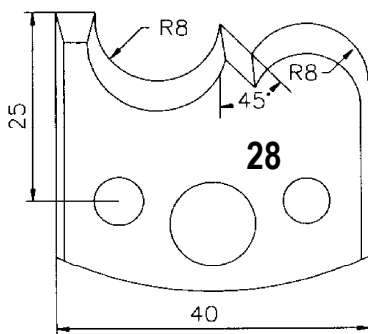

119N28 / 119C28

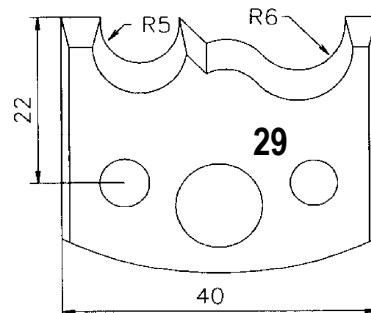

119N29 / 119C29

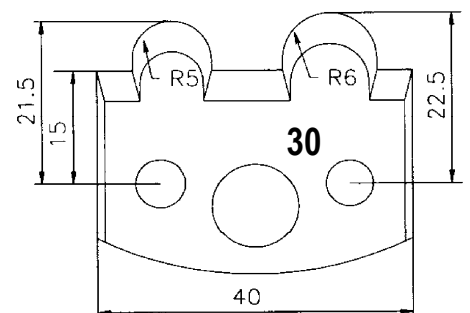

119N30 / 119C30

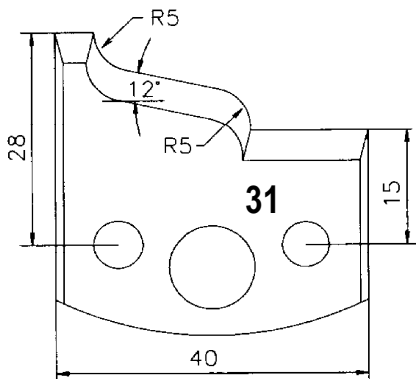

119N31 / 119C31

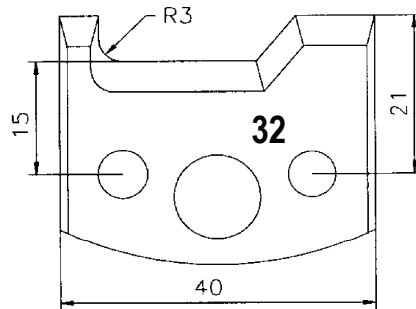

119N32 / 119C32

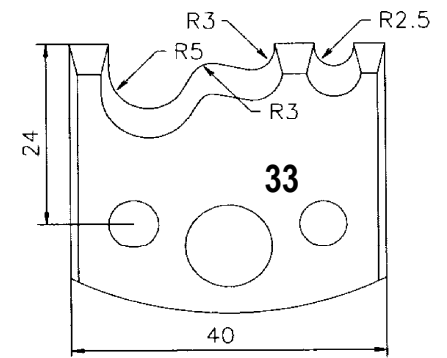

119N33 / 119C33

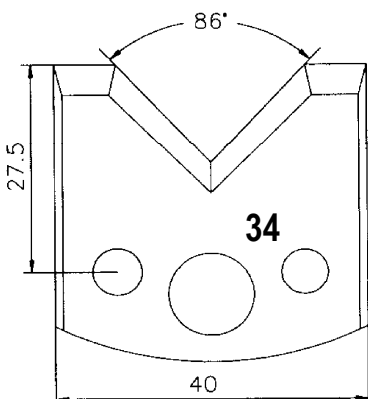

119N34 / 119C34

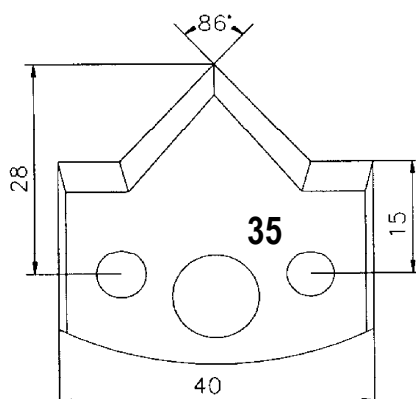

119N35 / 119C35

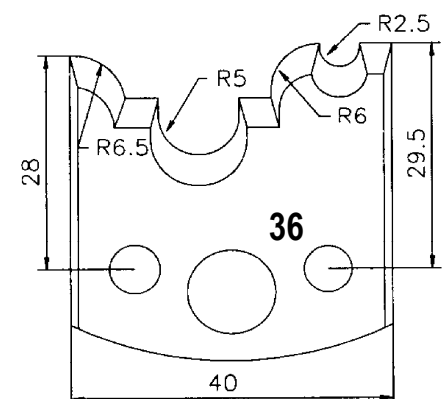

119N36 / 119C36

# COLTELLI PROFILATI DA 40 x 4 mm

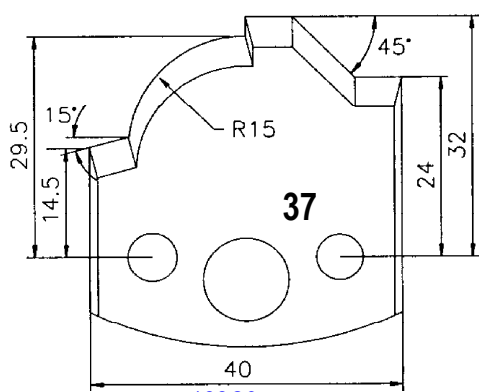

122N37 / 122C37

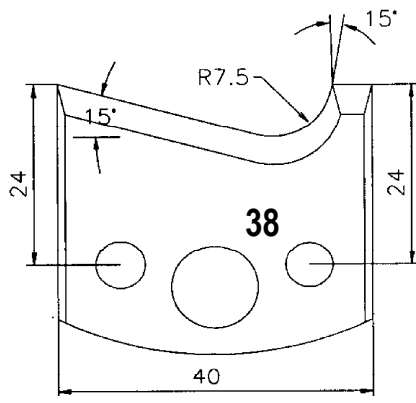

122N38 / 122C38

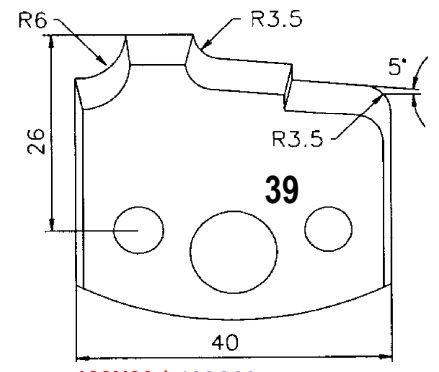

122N39 / 122C39

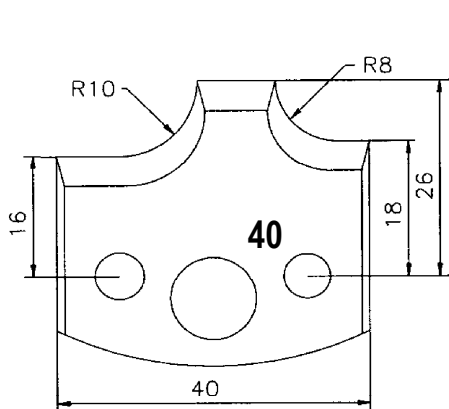

122N40 / 122C40

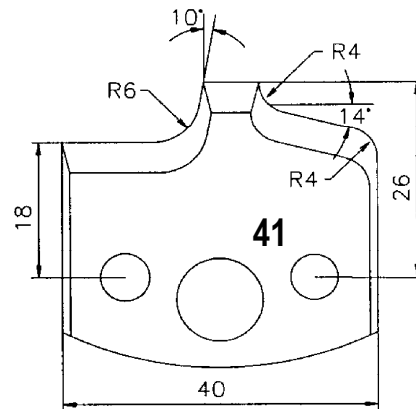

122N41 / 122C41

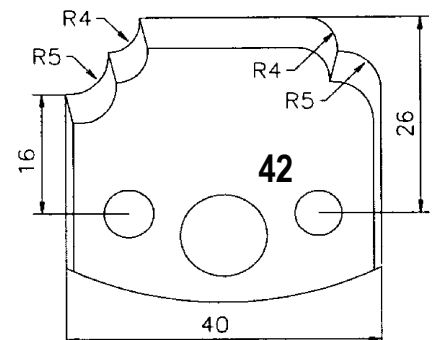

122N42 / 122C42

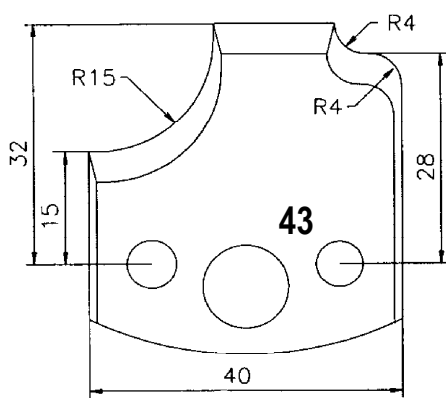

122N43 / 122C43

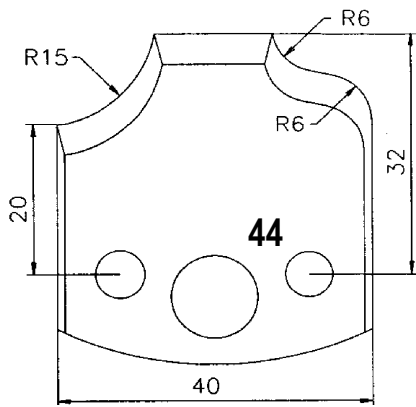

122N44 / 122C44

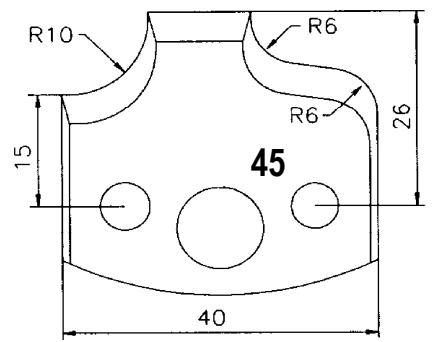

122N45 / 122C45

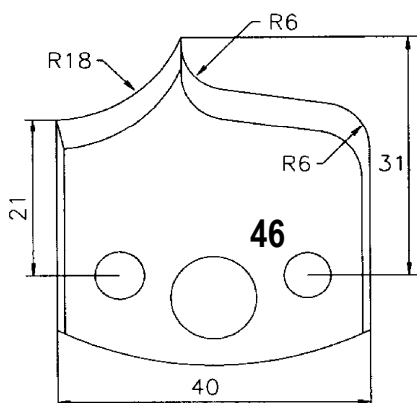

122N46 / 122C46

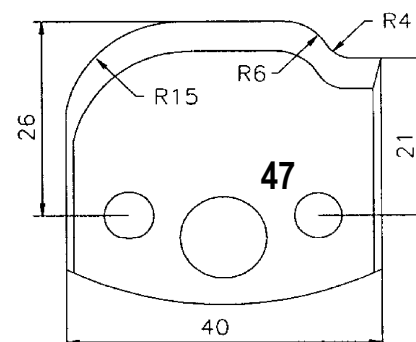

122N47 / 122C47

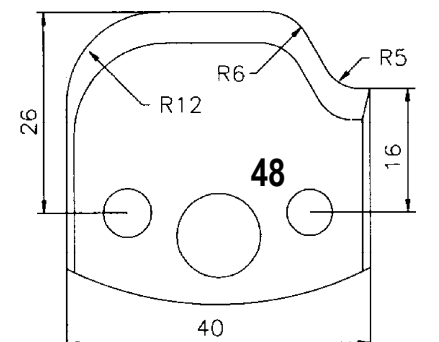

122N48 / 122C48

# COLTELLI PROFILATI DA 40 x 4 mm

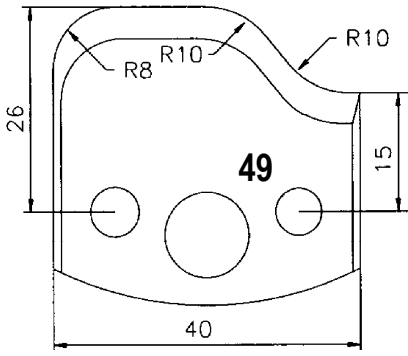

122N49 / 122C49

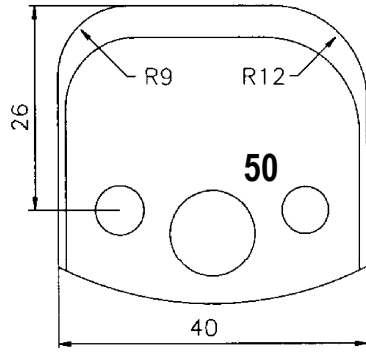

122N50 / 122C50

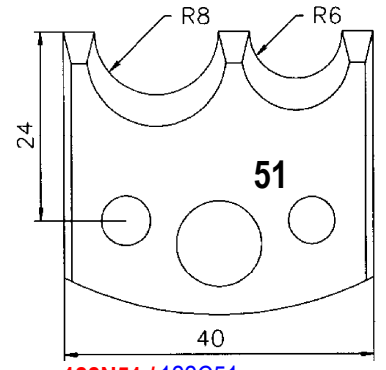

122N51 / 122C51

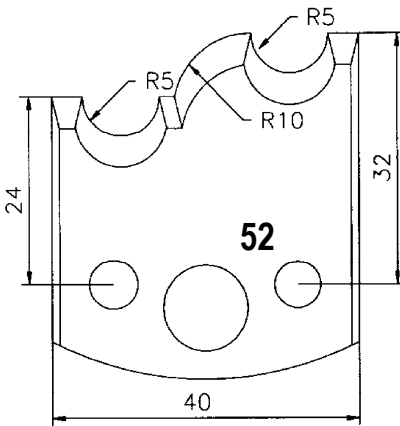

122N52 / 122C52

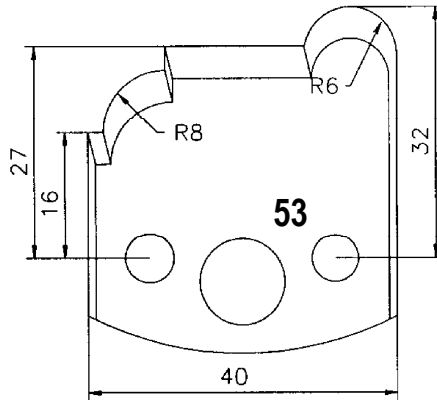

122N53 / 122C53

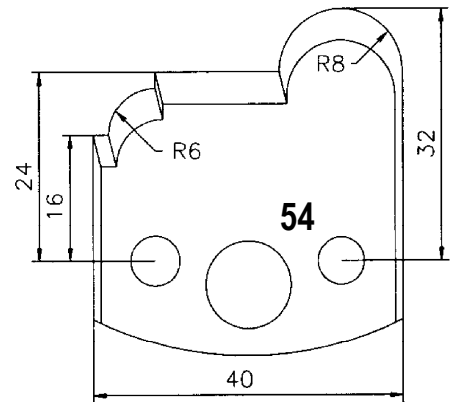

122N54 / 122C54

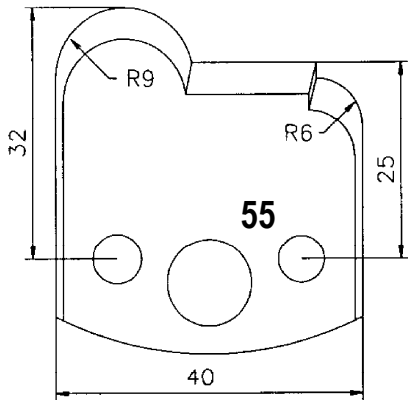

122N55 / 122C55

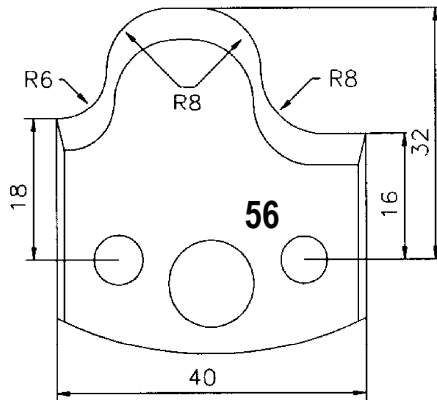

122N56 / 122C56

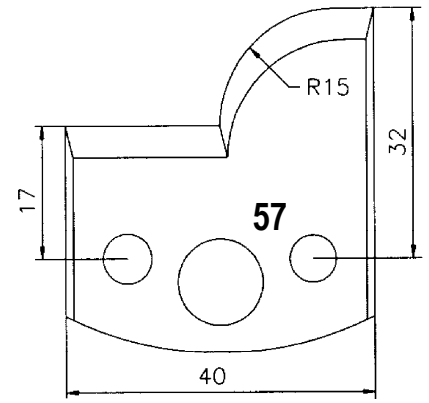

122N57 / 122C57

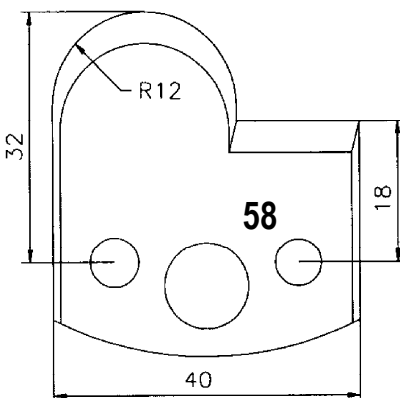

122N58 / 122C58

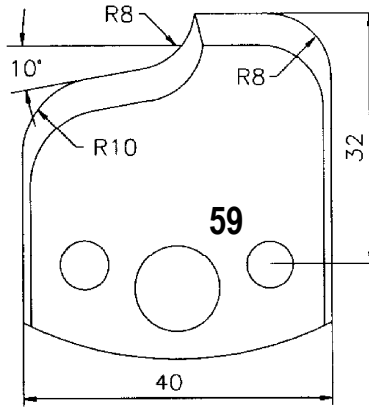

122N59 / 122C59

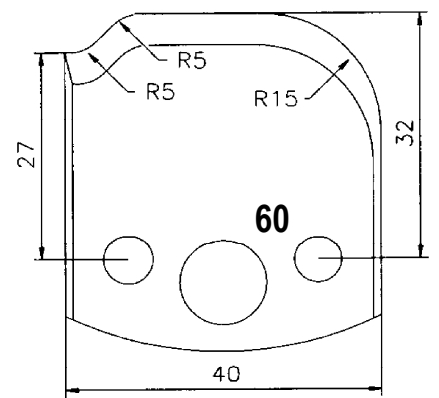

122N60 / 122C60

# COLTELLI PROFILATI DA 40 x 4 mm

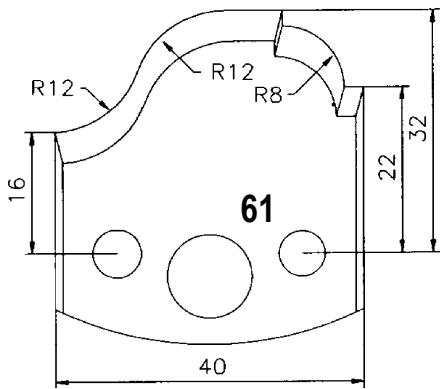

122N61 / 122C61

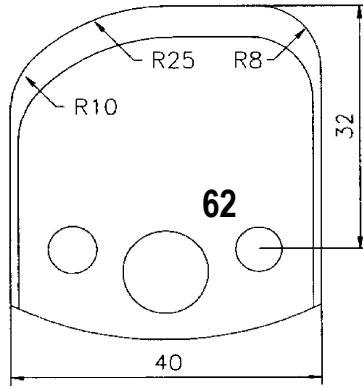

122N62 / 122C62

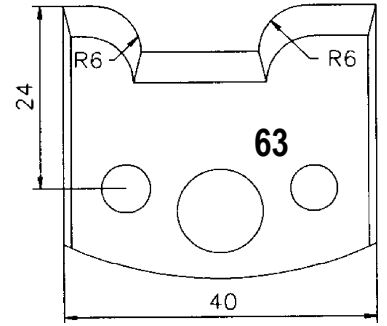

122N63 / 122C63

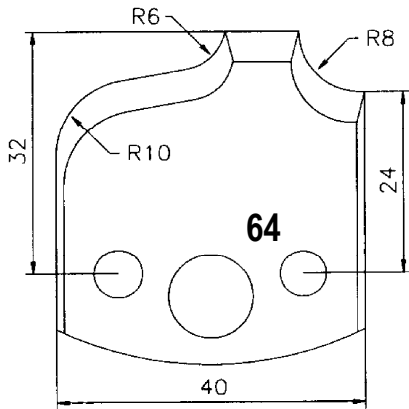

122N64 / 122C64

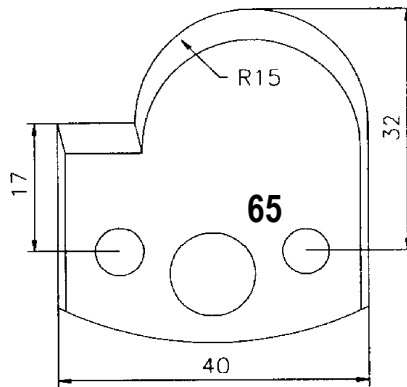

122N65 / 122C65

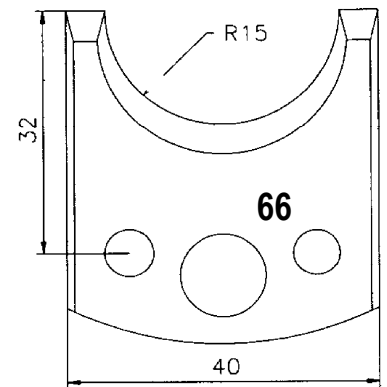

122N66 / 122C66

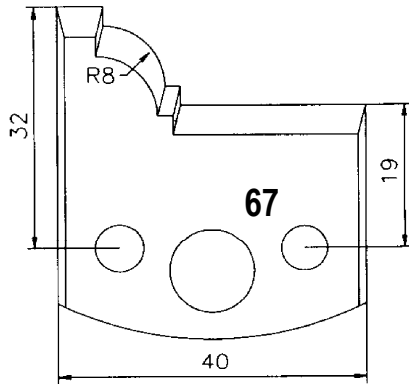

122N67 / 122C67

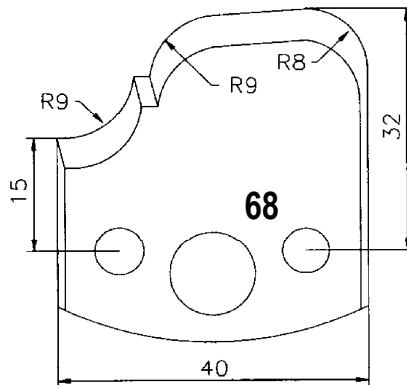

122N68 / 122C68

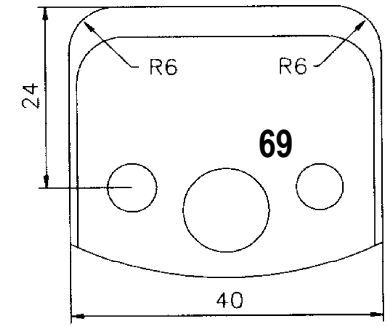

122N69 / 122C69

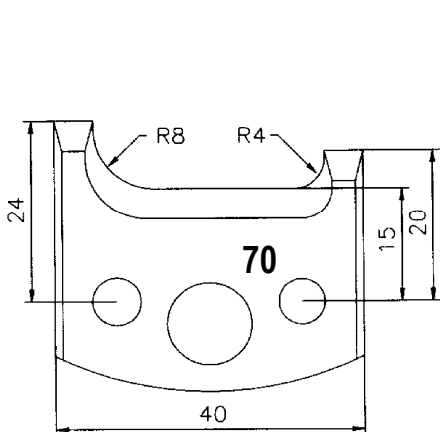

122N70 / 122C70

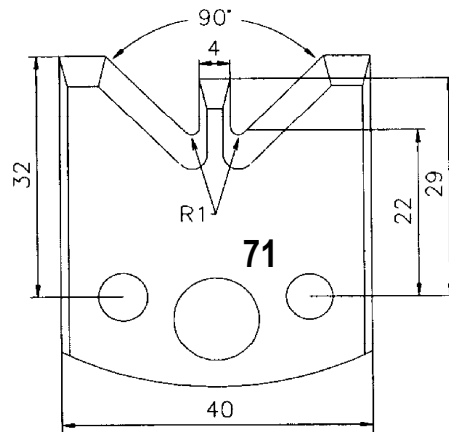

120N71 / 120C70

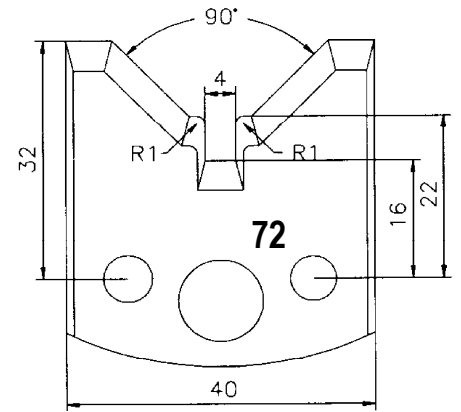

120N72 / 120C71

# COLTELLI PROFILATI DA 40 x 4 mm

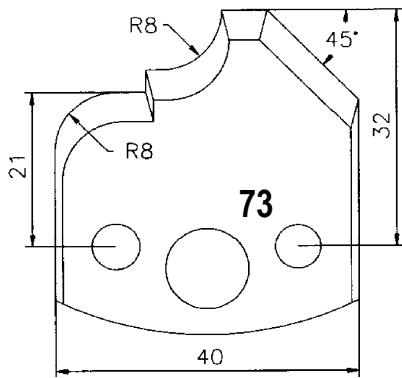

122N73 / 122C73

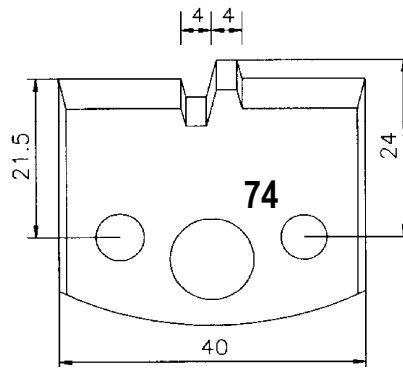

122N74 / 122C74

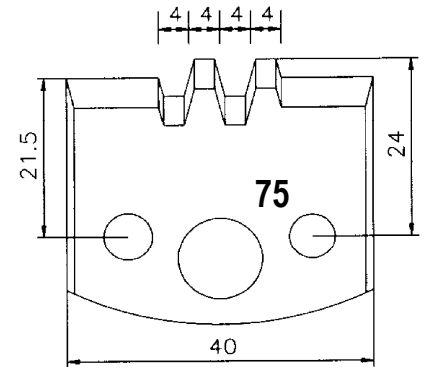

122N75 / 122C75

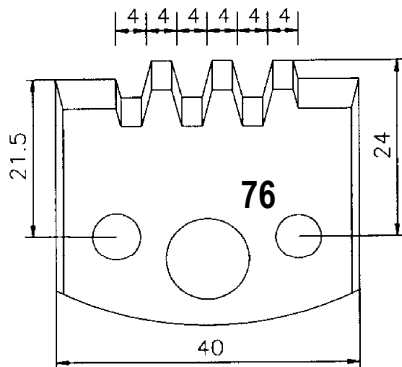

122N76 / 122C76

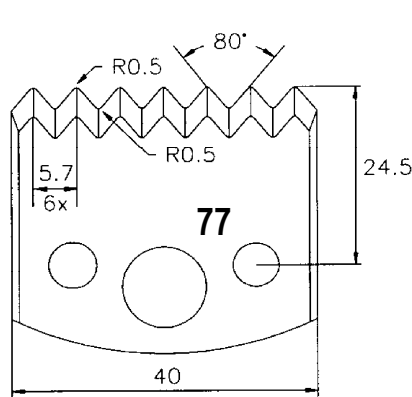

122N77 / 122C77

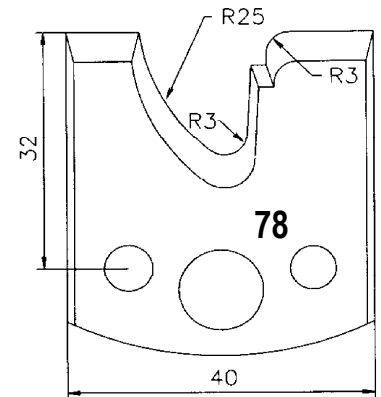

122N78 / 122C78

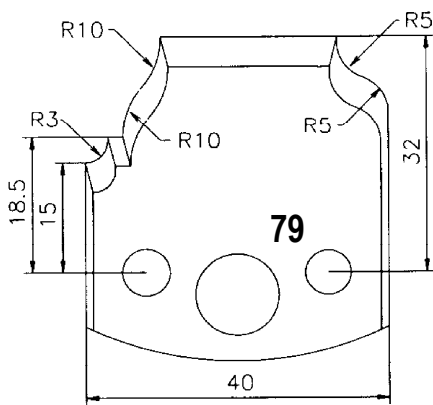

122N79 / 122C79

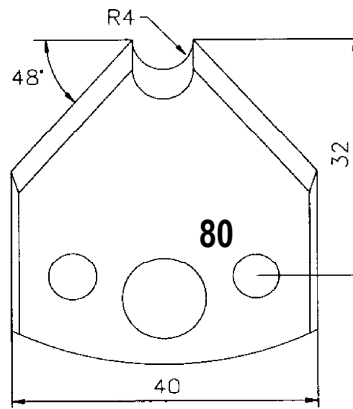

122N80 / 122C80

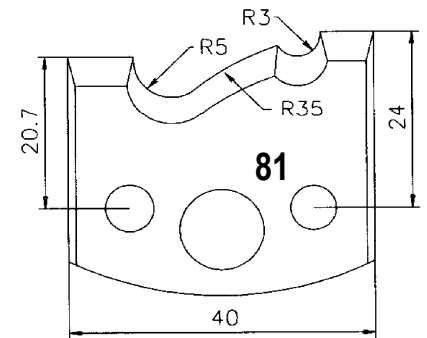

122N81 / 122C81

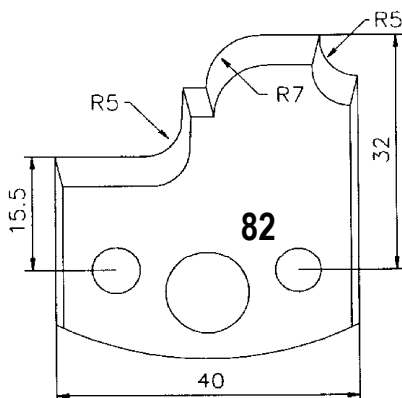

122N82 / 122C82

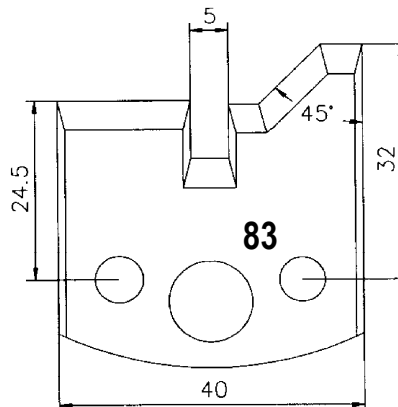

120N83 / 120C83

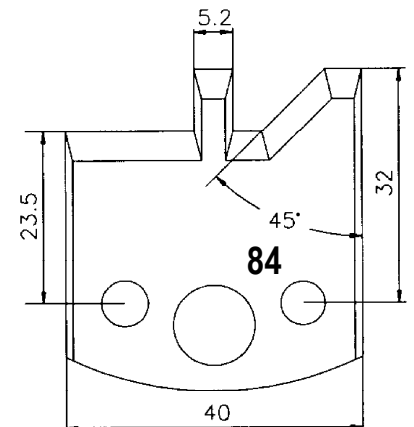

120N84 / 120C84

# COLTELLI PROFILATI DA 40 x 4 mm

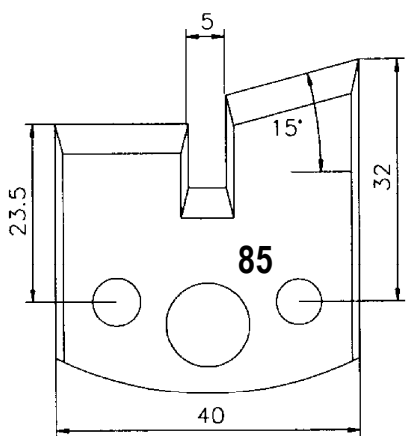

120N85 / 120C85

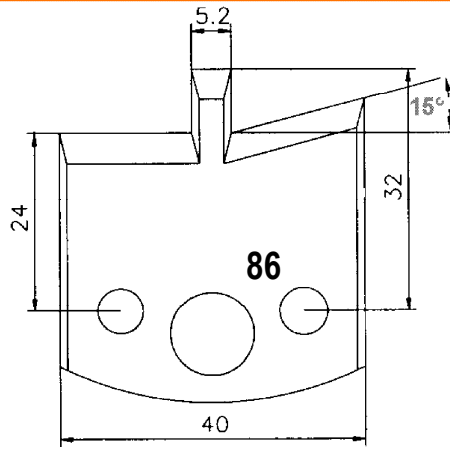

120N86 / 120C86

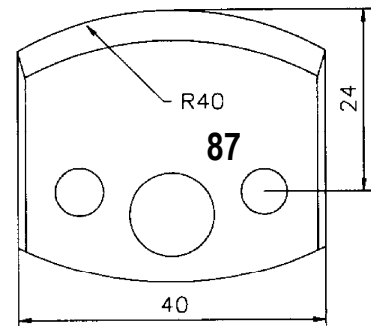

122N87 / 122C87

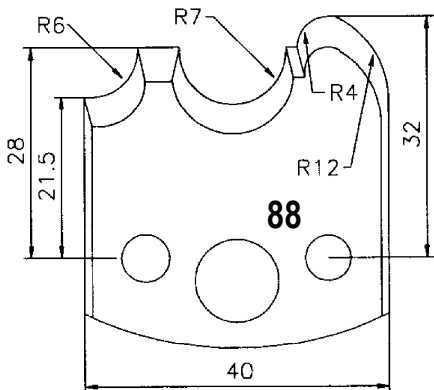

122N88 / 122C88

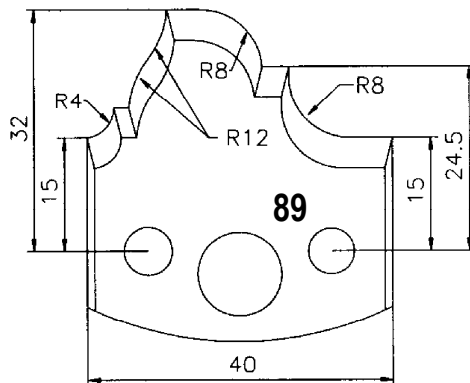

122N89 / 122C89

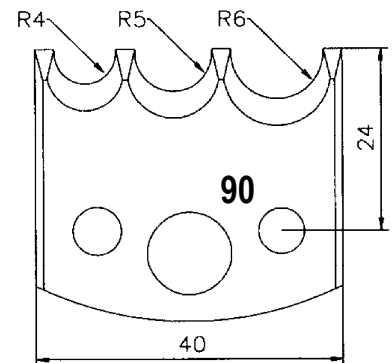

122N90 / 122C90

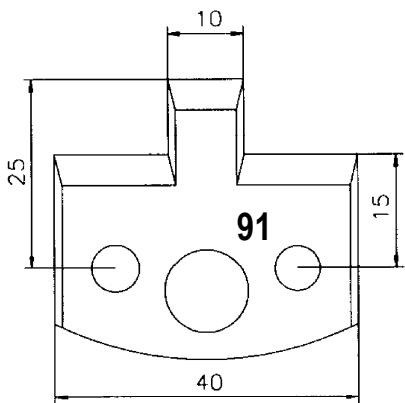

120N91 / 120C91

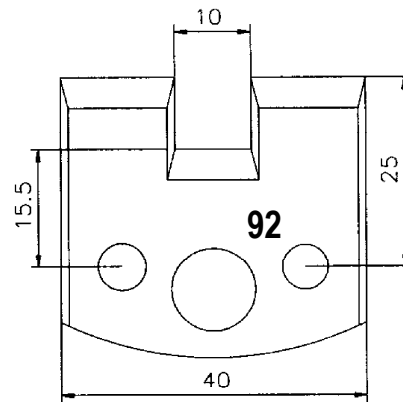

120N92 / 120C92

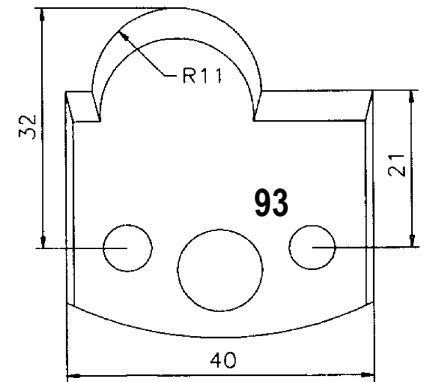

120N93 / 120C93

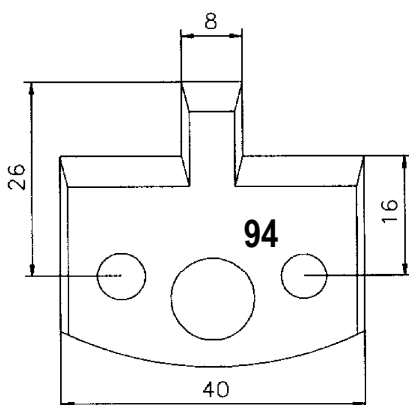

120N94 / 120C94

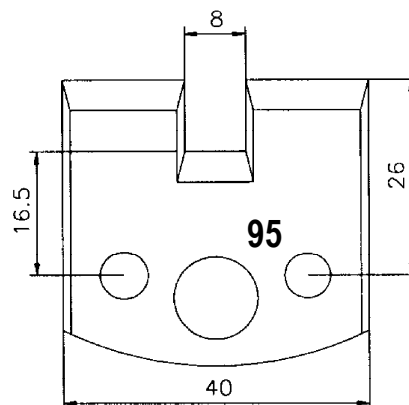

120N95 / 120C95

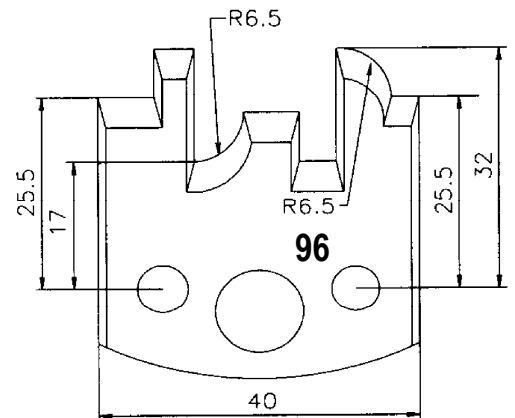

123N96 / 123C96



# COLTELLI PROFILATI DA 40 x 4 mm

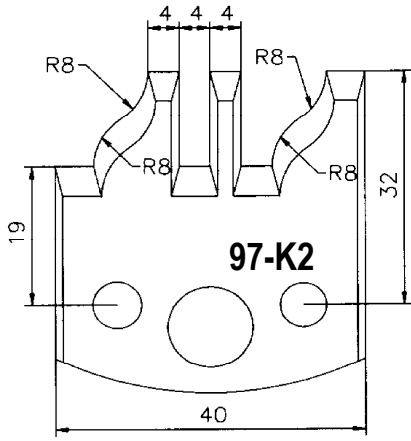

123N97 / 123C97

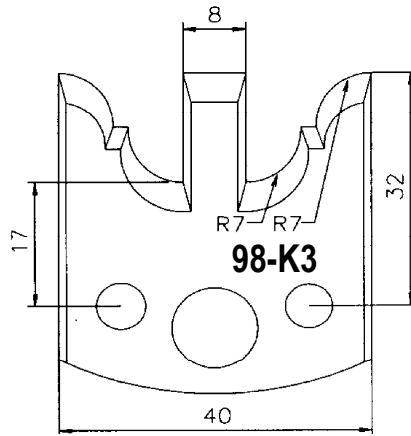

123N98 / 123C98

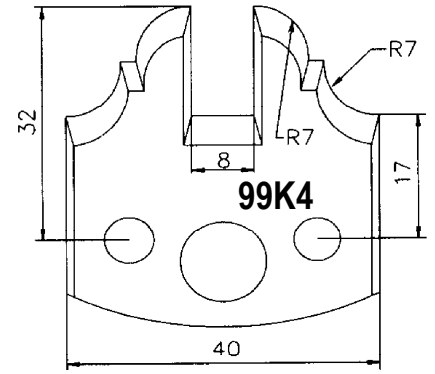

123N99 / 123C99

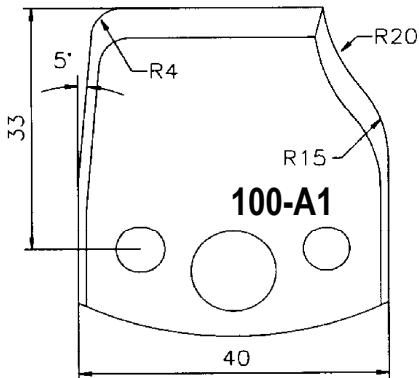

123N100 / 123C100

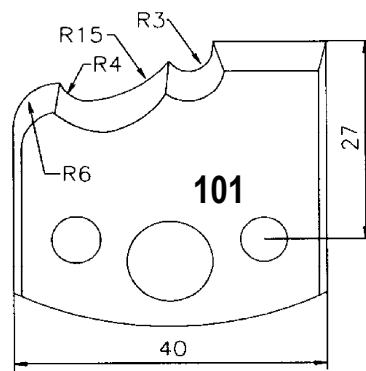

120N101 / 120C101

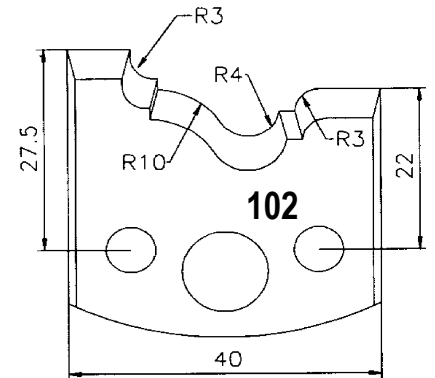

120N102 / 120C102

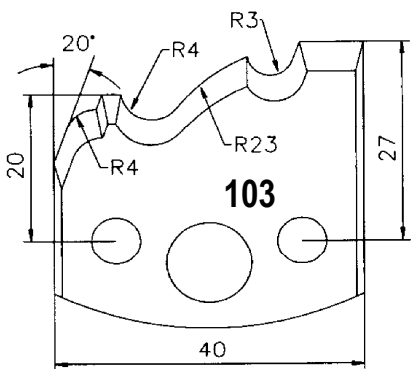

120N103 / 120C103

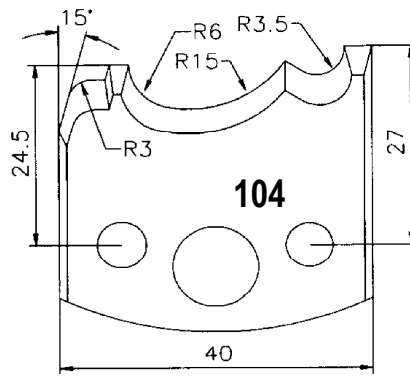

120N104 / 120C104

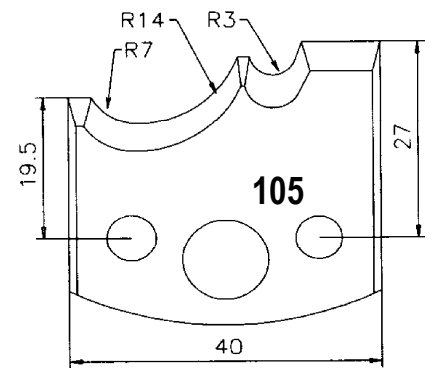

120N105 / 120C105

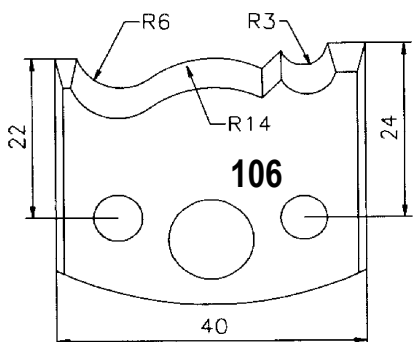

120N106 / 120C106

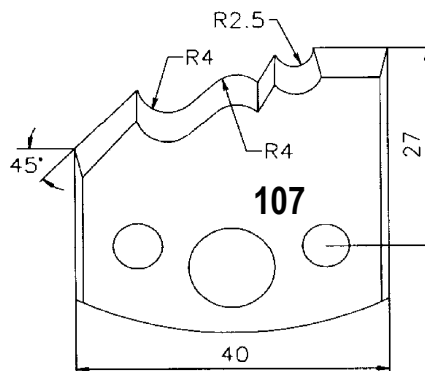

120N107 / 120C107

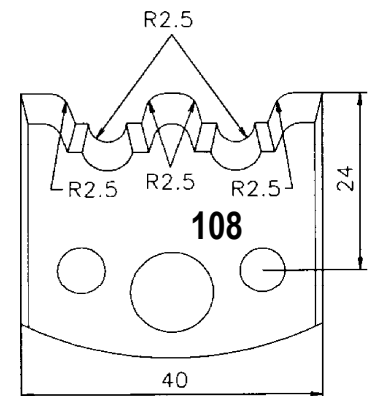

120N108 / 120C108

# COLTELLI PROFILATI DA 40 x 4 mm

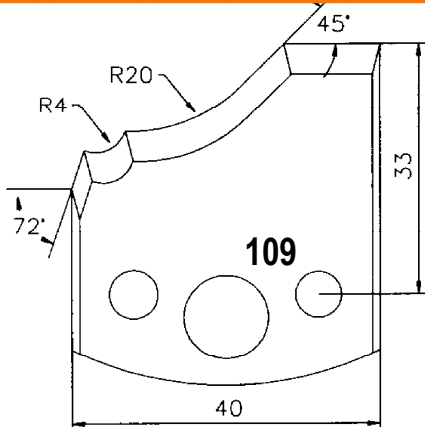

120N109 / 120C109

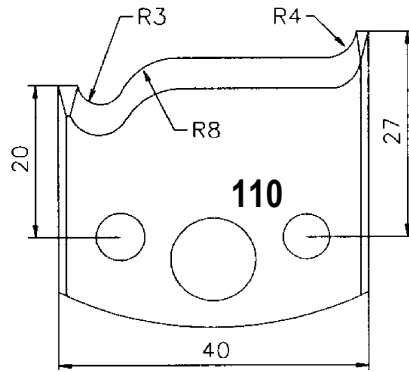

120N110 / 120C110

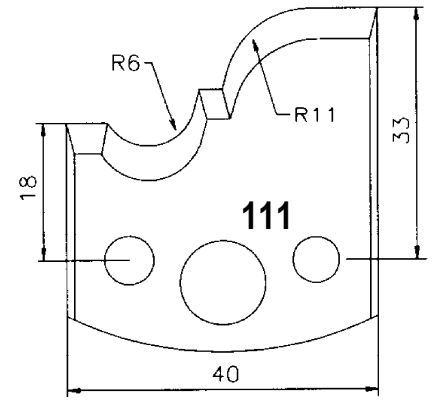

120N111 / 120C111

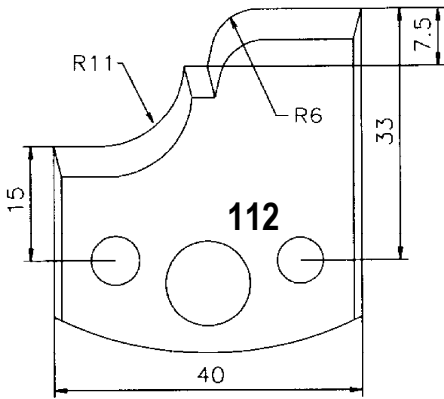

120N112 / 120C112

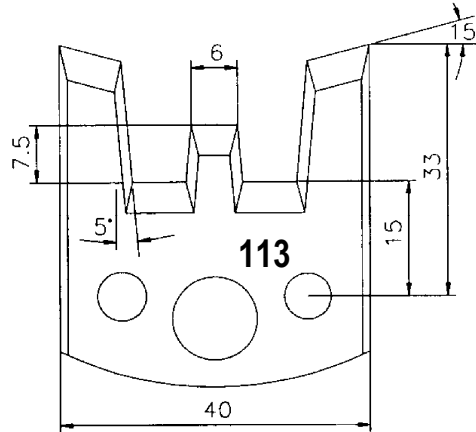

120N113 / 120C113

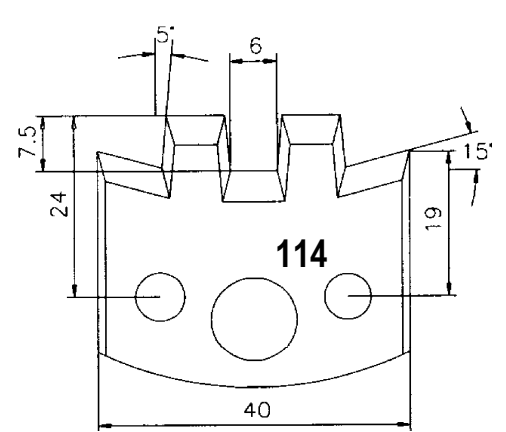

120N114 / 120C114

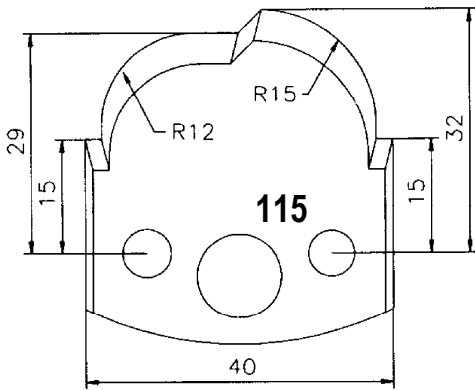

120N115 / 120C115

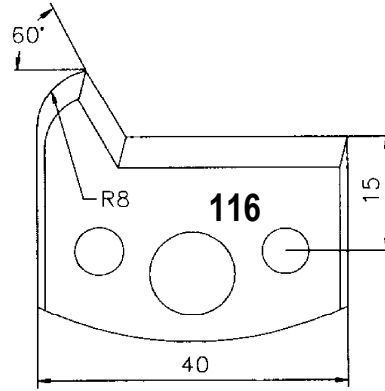

120N116 / 120C116

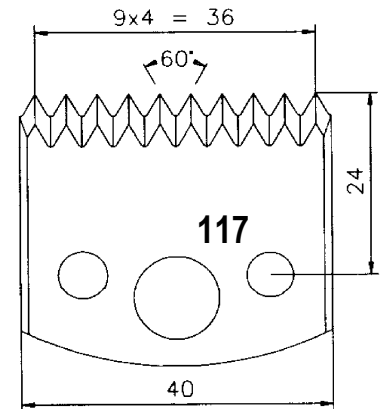

120N117 / 120C117

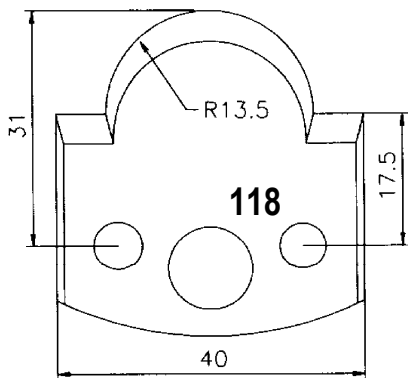

120N118 / 120C118

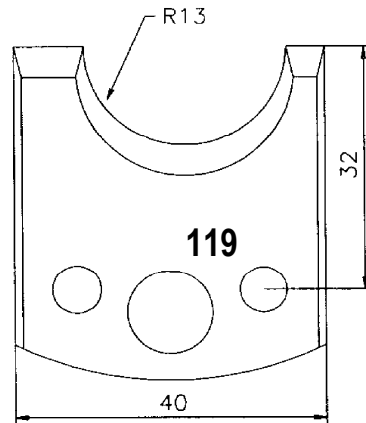

120N119 / 120C119

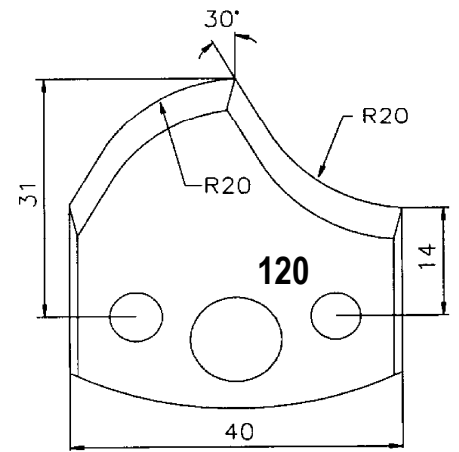

120N120 / 120C120

# COLTELLI PROFILATI DA 40 x 4 mm

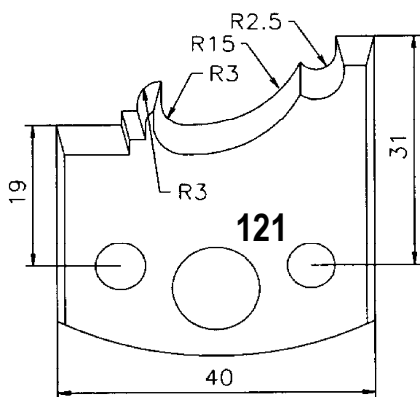

120N121 / 120C121

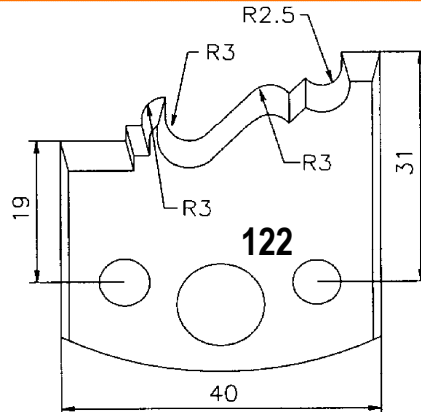

120N122 / 120C122

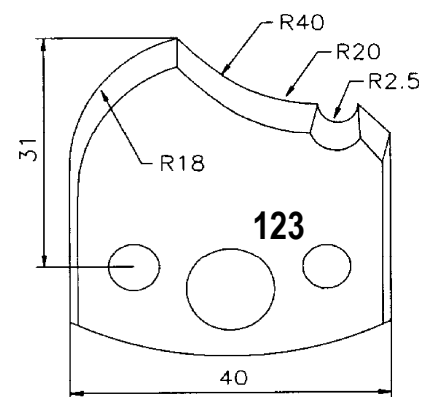

120N123 / 120C123

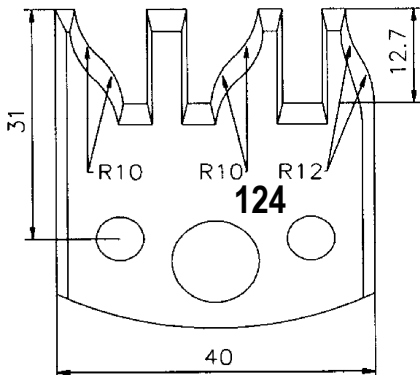

123N124 / 123C124

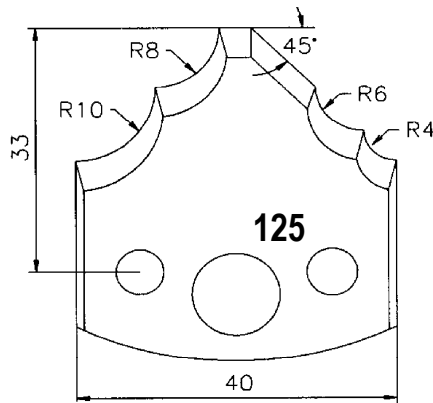

120N125 / 120C125

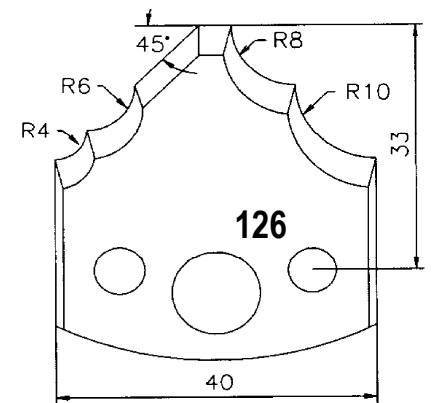

120N126 / 120C126

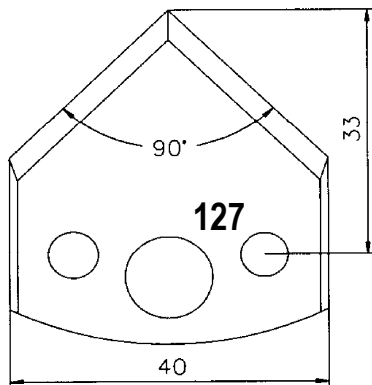

120N127 / 120C127

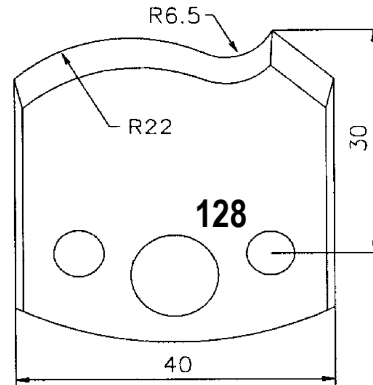

120N128 / 120C128

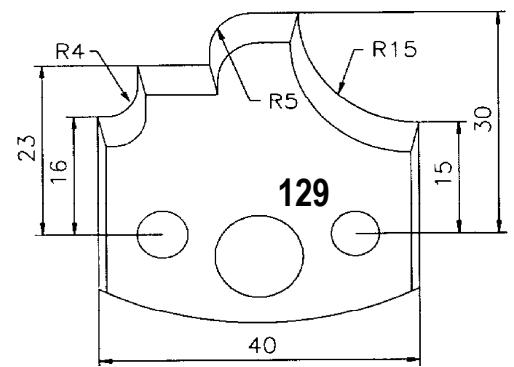

120N129 / 120C129

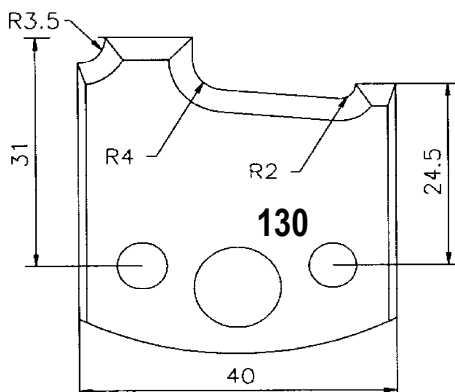

120N130 / 120C130

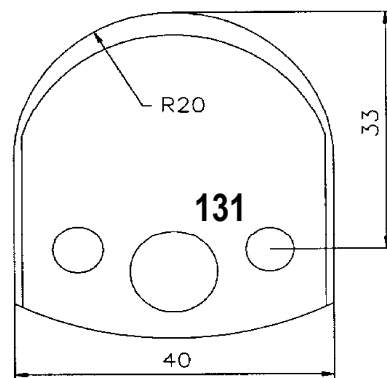

120N131 / 120C131

# COLTELLI PROFILATI DA 40 x 4 mm

